

REVISION			
REV	DESCRIPTION	DATE	APPROVED
A	RELEASE	07/21/21	JCM
B	ECO 010028 TAPPED HOLE REMOVED	10/21/21	JCM

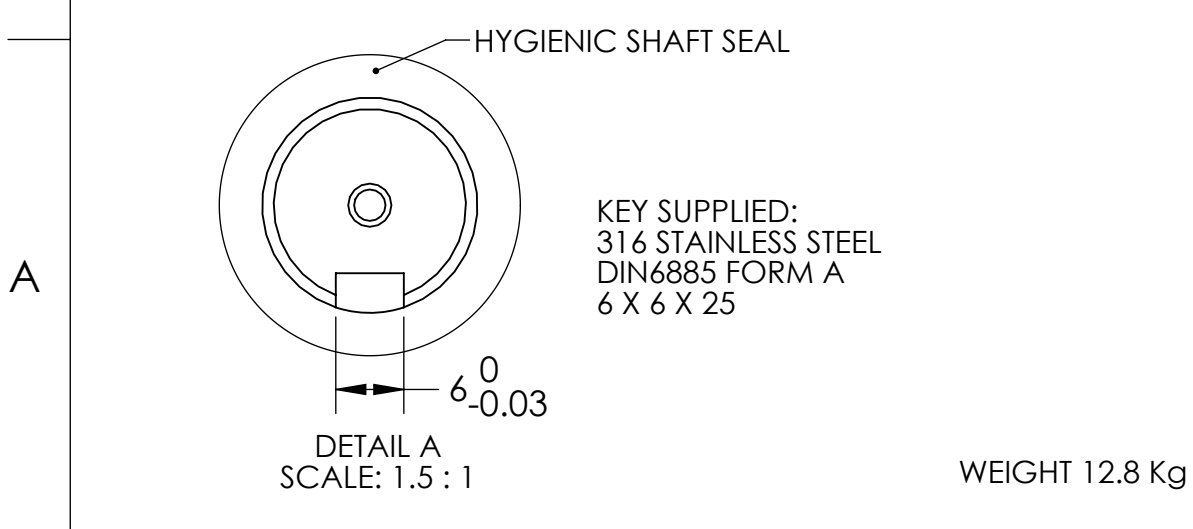
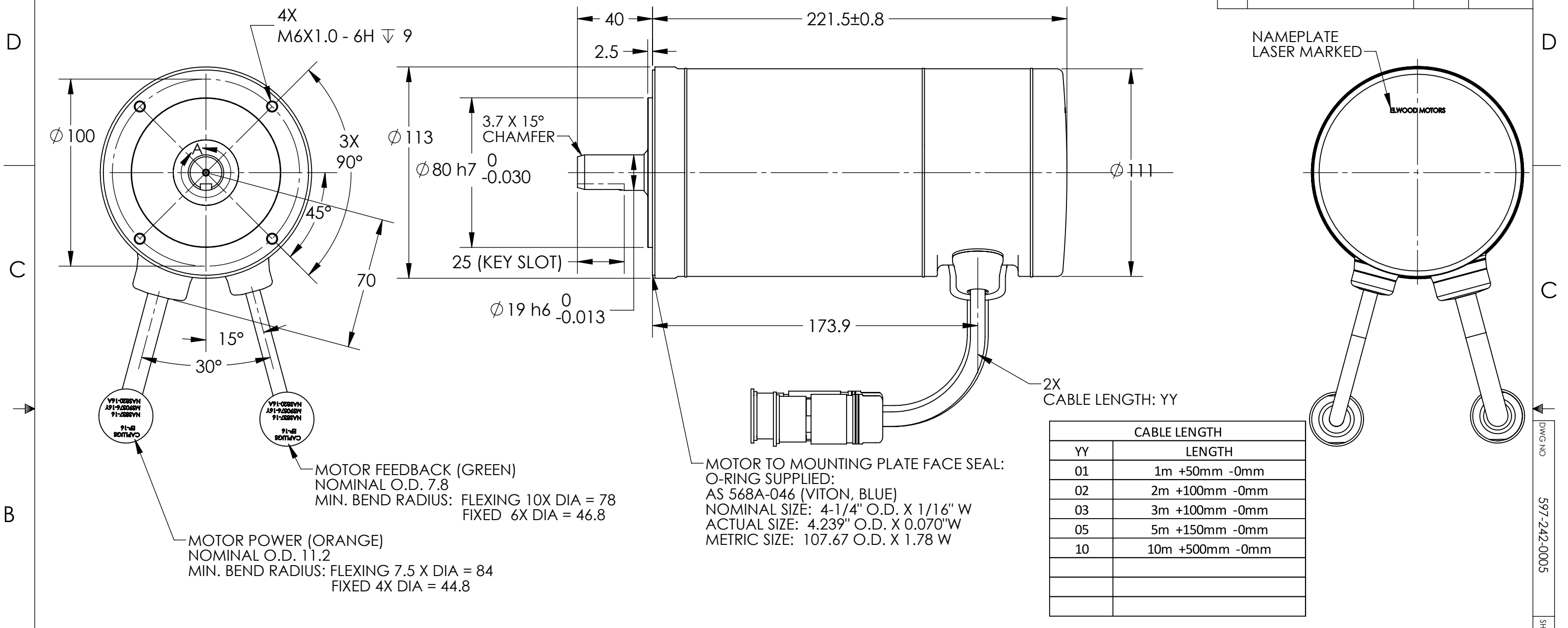

MOUNTING POSITIONS:
 IM 3601 (IM B14) HORIZONTAL SHAFT, STRAIN RELIEF'S MOTOR HOUSING FLATS CAN NOT BE HORIZONTAL
 IM 3611 (IM V18) VERTICAL SHAFT FACING DOWN
 IM 3631 (IM V19) VERTICAL SHAFT FACING UP IF MOTOR IS MOUNTED TO GEARBOX or PROVIDED SHAFT/SEAL AREA IS EXCLUDED FROM HYGIENIC REQUIREMENTS

FIRST USED 999-001-2160	TOLERANCE UNLESS OTHERWISE SPECIFIED	DRAWN JCM 7/21/21	MFG. APPROVED	Elwood Corporation - Motors Group 2701 N. Green Bay Rd Racine, WI, U.S.A.	
MATERIAL	FRACTIONS 1/32 (.794 mm) .XX ±.01 (.254 mm) .XXX ±.005 (.127 mm) .XXXX ±.0005 (.0127 mm)	CHECKED	OTHER APPROVED		
FINAL FINISH	ANGLES ±1 DEGREE	ENG. APPROVED	997- 997-003-0175	SIZE B	SOLIDWORKS CAD
NOTE: UNLESS OTHERWISE SPECIFIED. 1. REMOVE ALL BURRS AND SHARP EDGES. 2. CHAMFER FIRST THD. ALL TAPPED HOLES. 3. 4.	SURFACE FINISH OR BETTER 125 ✓	"THIS DOCUMENT AND ALL INFORMATION CONTAINED OR IMPLIED HERIN IS THE PROPERTY OF ELWOOD CORP. IT SHALL NOT BE DUPLICATED OR COMMUNICATED TO OTHERS NOR USED FOR PURPOSES OTHER THAN THOSE FOR WHICH IT WAS SPECIFICALLY FURNISHED."		PART NO 597-242-0005	SCALE NONE EDN 073721 SHEET 1 OF 1

DWG NO 597-242-0005 SH 1