

REVISION			
REV	DESCRIPTION	DATE	APPROVED
A	RELEASE	8/26/20	JCM

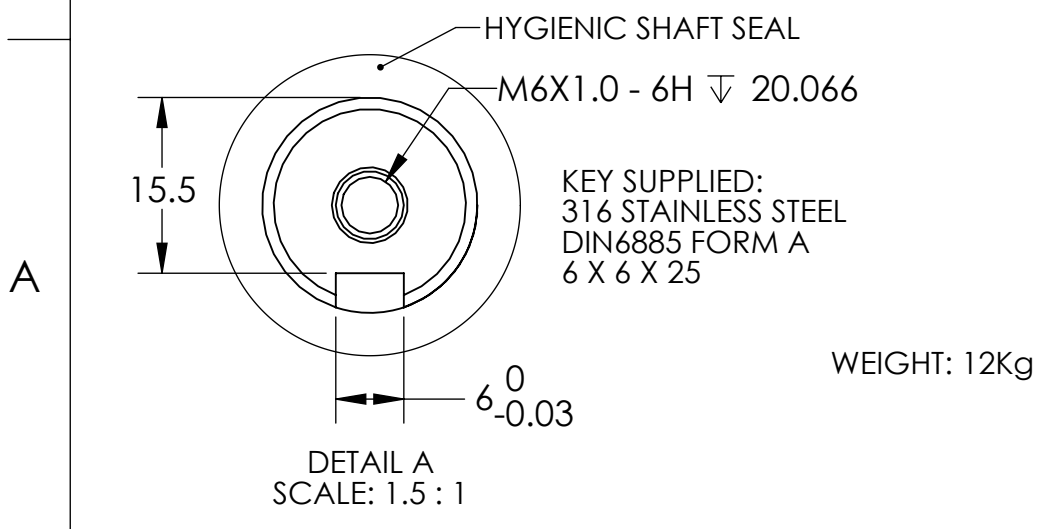
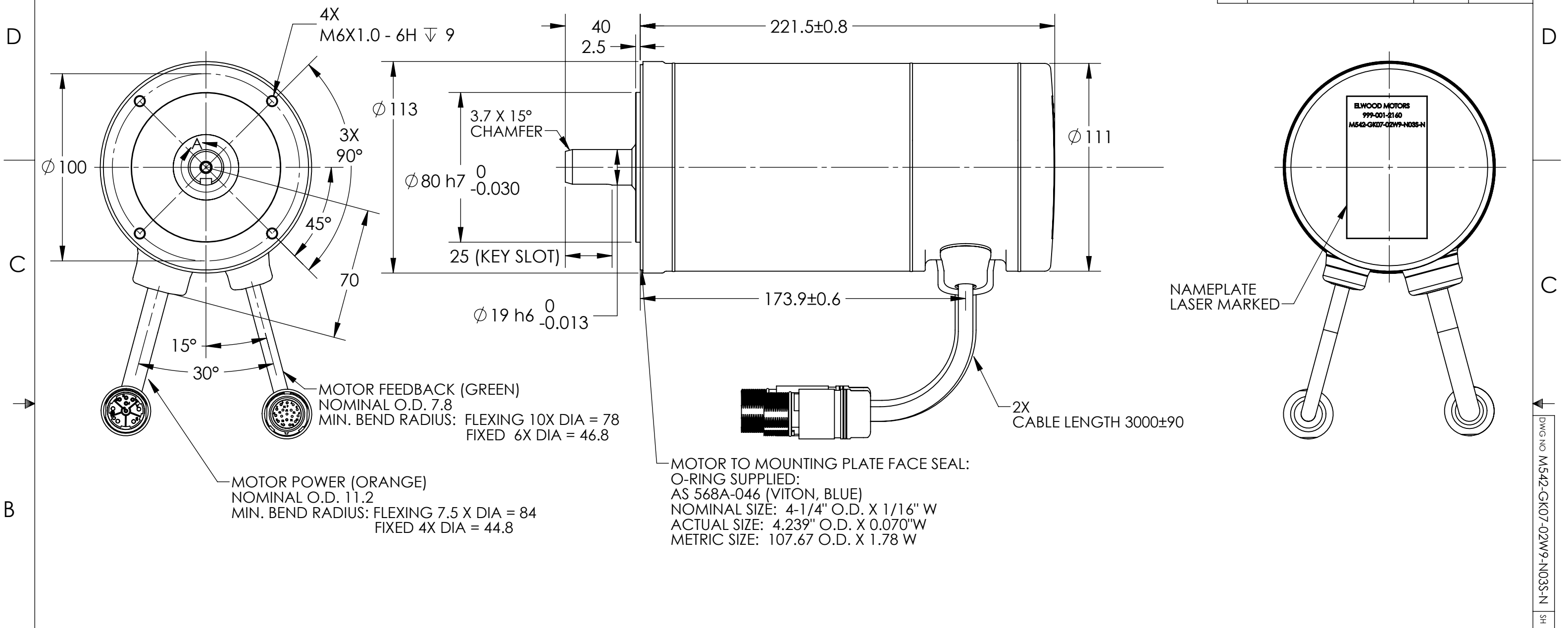

MOUNTING POSITIONS:  
 IM 3601 (IM B14) HORIZONTAL SHAFT, STRAIN RELIEF'S MOTOR HOUSING FLATS CAN NOT BE HORIZONTAL  
 IM 3611 (IM V18) VERTICAL SHAFT FACING DOWN  
 IM 3631 (IM V19) VERTICAL SHAFT FACING UP IF MOTOR IS MOUNTED TO GEARBOX or PROVIDED SHAFT/SEAL AREA IS EXCLUDED FROM HYGIENIC REQUIREMENTS

FIRST USED 999-001-2160	TOLERANCE UNLESS OTHERWISE SPECIFIED	DRAWN JCM 8/25/20	MFG. APPROVED	Elwood Corporation - Motors Group 2701 N. Green Bay Rd Racine, WI, U.S.A	
MATERIAL	FRACTIONS 1/32 (.794 mm) .XX $\pm .01$ (.254 mm) .XXX $\pm .005$ (.127 mm) .XXXX $\pm .0005$ (.0127 mm)	CHECKED	OTHER APPROVED		
FINAL FINISH	ANGLES $\pm 1$ DEGREE	ENG. APPROVED	997- 997-002-9868	SIZE B	SOLIDWORKS CAD
NOTE: UNLESS OTHERWISE SPECIFIED. 1. REMOVE ALL BURRS AND SHARP EDGES. 2. CHAMFER FIRST THD. ALL TAPPED HOLES. 3. 4.	SURFACE FINISH OR BETTER $\checkmark 125$	"THIS DOCUMENT AND ALL INFORMATION CONTAINED OR IMPLIED HERIN IS THE PROPERTY OF ELWOOD CORP. IT SHALL NOT BE DUPLICATED OR COMMUNICATED TO OTHERS NOR USED FOR PURPOSES OTHER THAN THOSE FOR WHICH IT WAS SPECIFICALLY FURNISHED."		PART NO M542-GK07-02W9-N03S-N	SCALE NONE EDN 072832 SHEET 1 OF 2

DWG NO M542-GK07-02W9-N03S-N SH 1

REVISION			
REV	DESCRIPTION	DATE	APPROVED
	SEE SHEET 1		

PIN	FUNCTION	REF-MOTOR POWER CABLE (ORANGE)		
		CORES	CORE IDENTIFICATION	CORE SIZE
A	PHASE U	POWER SUPPLY CORES	BLACK WITH IMPRINT U/L1/C/L+	1mm <sup>2</sup>
B	PHASE V		BLACK WITH IMPRINT V/L2	1mm <sup>2</sup>
C	PHASE W		BLACK WITH IMPRINT W/L3/D/L-	1mm <sup>2</sup>
GND	GROUND		GREEN & YELLOW STRIPES	1mm <sup>2</sup>
E	NOT USED			
F	BRAKE (OPTIONAL)	CONTROL CORE	BLACK WITH NUMBER 7	0.75mm <sup>2</sup>
G	BRAKE (OPTIONAL)	PAIR 2	BLACK WITH NUMBER 8	0.75mm <sup>2</sup>
H	NOT USED	CONTROL CORE	BLACK WITH NUMBER 5	0.75mm <sup>2</sup>
L	NOT USED	PAIR 1	BLACK WITH NUMBER 6	0.75mm <sup>2</sup>

NOTE: CCW SHAFT ROTATION FACING FRONT FLANGE OF MOTOR

SPEEDTEC CONNECTOR PIN	ENCODER FUNCTION	MOTOR FEEDBACK CABLE (GREEN)		
		CORE IDENTIFICATION	DESIGNATION	CORE SIZE
1	PS	RED	PAIR 7	0.18mm <sup>2</sup>
2	/PS	ORANGE		0.18mm <sup>2</sup>
3	BAT(-)	GREEN	PAIR 6	0.18mm <sup>2</sup>
4	BAT(+)	YELLOW		0.18mm <sup>2</sup>
5	FG	BLACK	PAIR 8	0.18mm <sup>2</sup>
6	N.C.	BROWN		0.18mm <sup>2</sup>
7	N.C.	WHITE/YELLOW	PAIR 1	0.18mm <sup>2</sup>
8	N.C.	WHITE/GREEN		0.18mm <sup>2</sup>
9	N.C.	WHITE/RED	PAIR 2	0.18mm <sup>2</sup>
10	N.C.	WHITE/ORANGE		0.18mm <sup>2</sup>
11	PG 5V	WHITE/BLACK	PAIR 3	0.18mm <sup>2</sup>
12	PG 0V	WHITE/BROWN		0.18mm <sup>2</sup>
13	N.C.	GRAY	PAIR 4	0.18mm <sup>2</sup>
14	N.C.	WHITE		0.18mm <sup>2</sup>
15	N.C.	BLUE	PAIR 5	0.18mm <sup>2</sup>
16	N.C.	VIOLET		0.18mm <sup>2</sup>
17	N.C.			

FIRST USED 999-001-2160	TOLERANCE UNLESS OTHERWISE SPECIFIED	DRAWN JCM 8/25/20	MFG. APPROVED	Elwood Corporation - Motors Group 2701 N. Green Bay Rd Racine, WI, U.S.A	
MATERIAL	FRACTIONS 1/32 (.794 mm) .XX ±.01 (.254 mm) .XXX ±.005 (.127 mm) .XXXX ±.0005 (.0127 mm)	CHECKED	OTHER APPROVED		
FINAL FINISH	ANGLES ±1 DEGREE	ENG. APPROVED	997-002-9868	SIZE B	PART NO M542-GK07-02W9-N03S-N
NOTE: UNLESS OTHERWISE SPECIFIED. 1. REMOVE ALL BURRS AND SHARP EDGES. 2. CHAMFER FIRST THD. ALL TAPPED HOLES. 3. 4.	SURFACE FINISH 125 ✓ OR BETTER	"THIS DOCUMENT AND ALL INFORMATION CONTAINED OR IMPLIED HERIN IS THE PROPERTY OF ELWOOD CORP. IT SHALL NOT BE DUPLICATED OR COMMUNICATED TO OTHERS NOR USED FOR PURPOSES OTHER THAN THOSE FOR WHICH IT WAS SPECIFICALLY FURNISHED."		SCALE NONE EDN 072832	

DWG NO M542-GK07-02W9-N03S-N SH 1