

REVISION			
REV	DESCRIPTION	DATE	APPROVED
A	PRODUCTION RELEASE	01/06/20	DAW
B	ECO009748; CHG NAMEPLATE	07/21/20	DAW

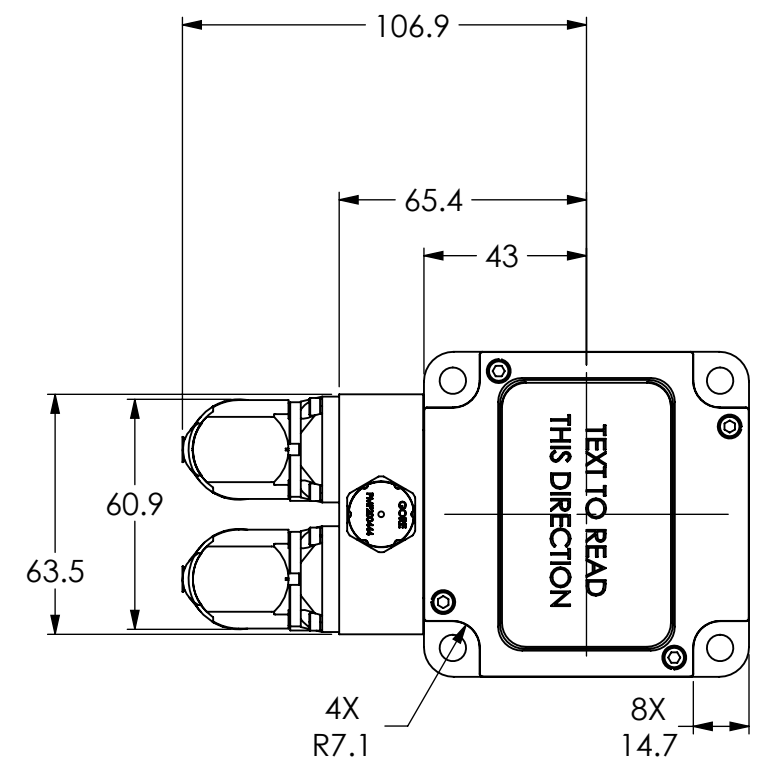

DATA	UNITS	MOTOR					
		M431		M432		M433	
		NO BRAKE	BRAKE	NO BRAKE	BRAKE	NO BRAKE	BRAKE
DIMENSION "X"	MM	137.4	198.8	175.5	236.9	213.6	275.0

NOTES:
 1. ALL DIMENSIONS ARE MM
 2. UNLESS SPECIFIC TOLERANCES ARE SHOWN, ALL DIMENSIONS ARE REFERENCE ONLY.

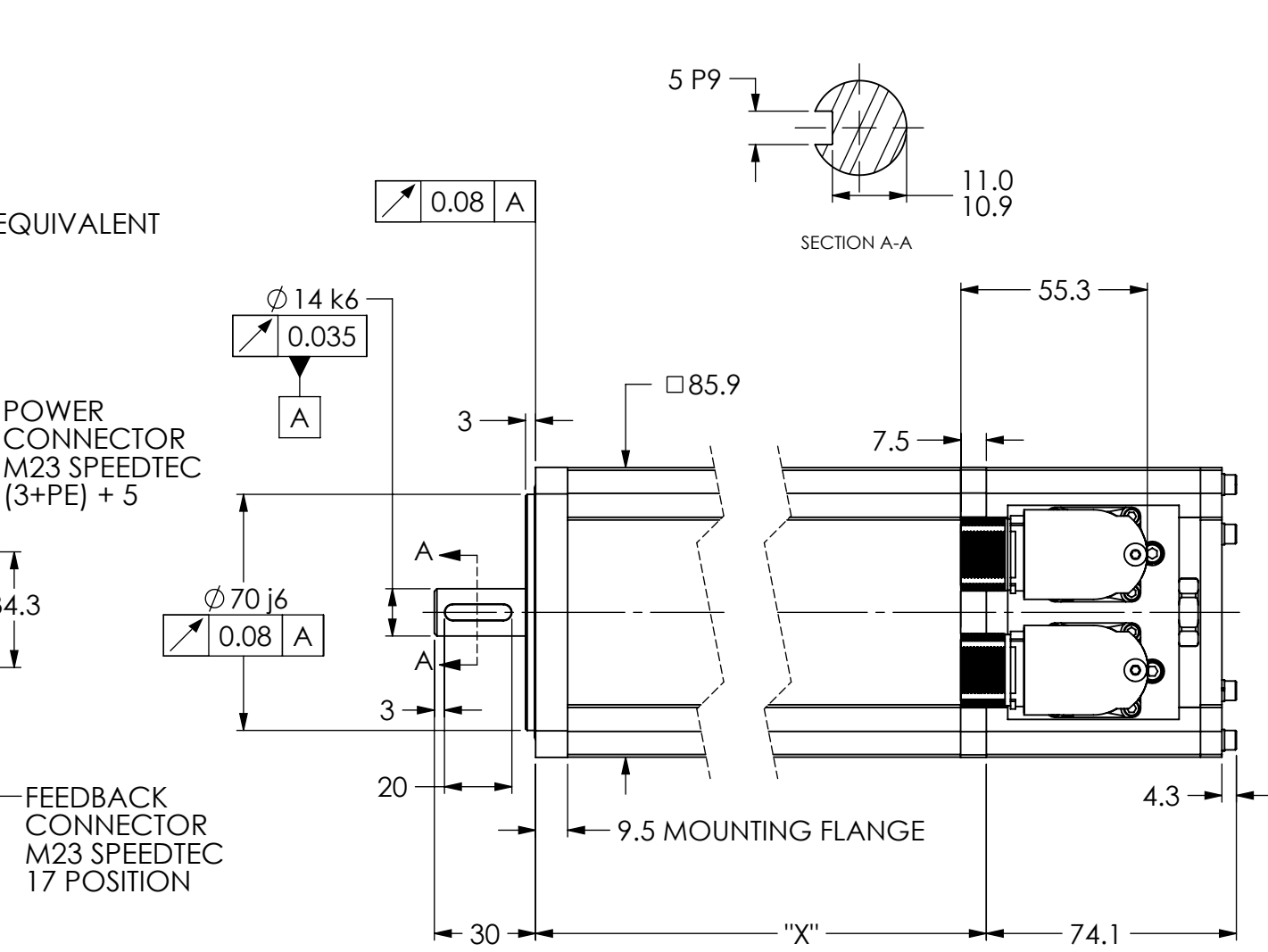
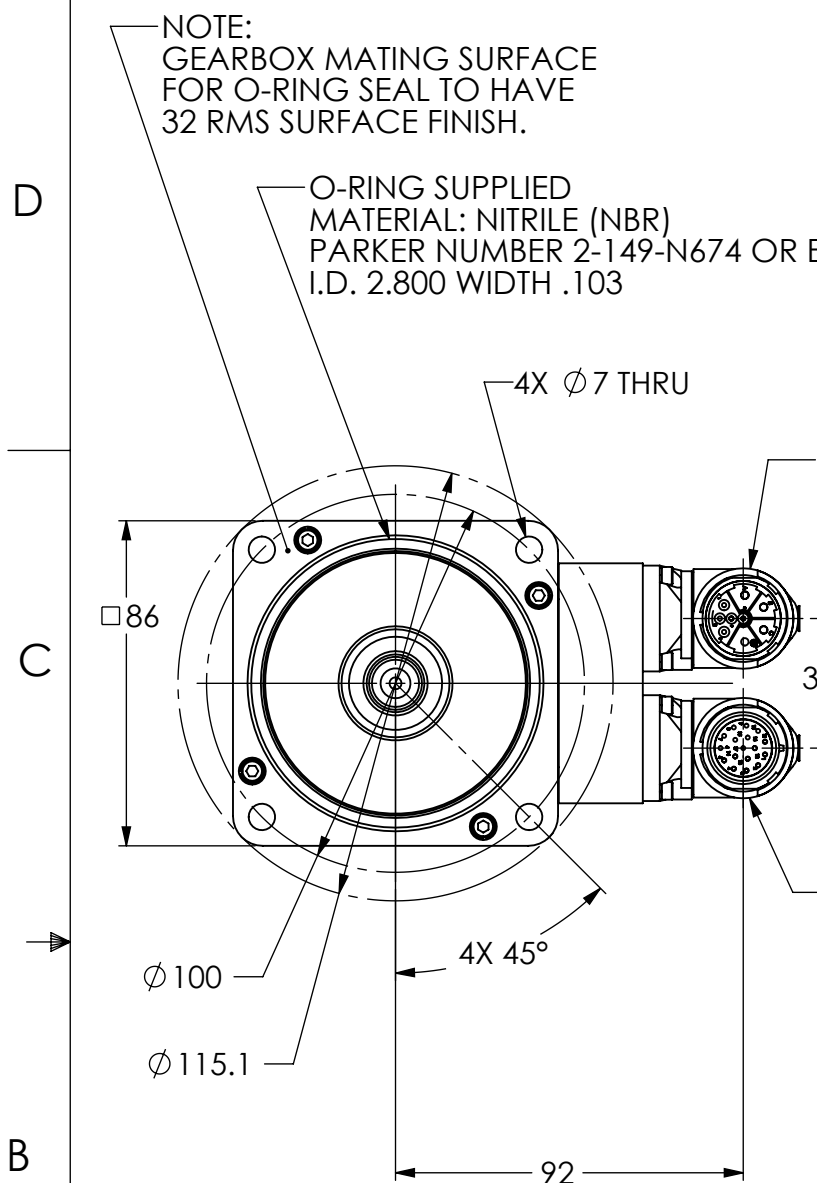
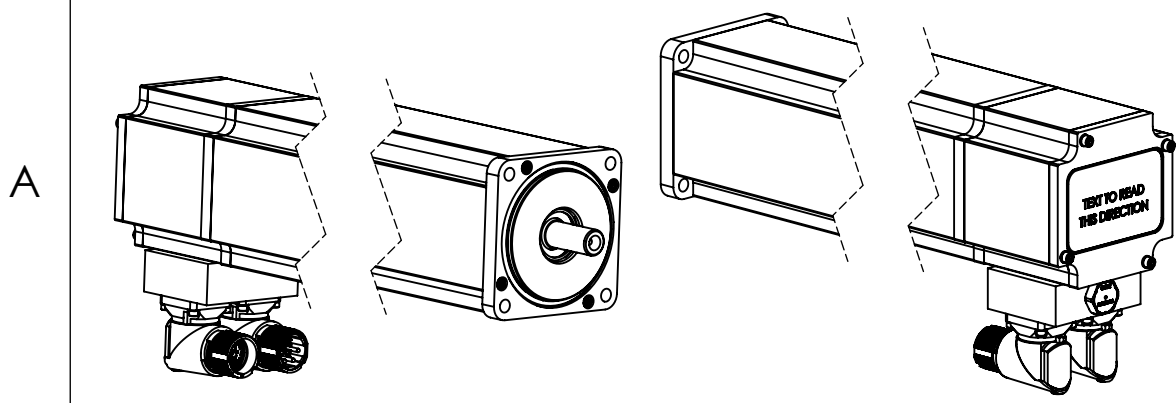

FIRST USED 999-001-1890 M431-NN0B-OWEN	TOLERANCE UNLESS OTHERWISE SPECIFIED	DRAWN DAW 01/06/20	MFG. APPROVED
MATERIAL	FRACTIONS 1/32 (.794 mm) .XX ±.01 (.254 mm) .XXX ±.005 (.127 mm) .XXXX ±.0005 (.0127 mm)	CHECKED	OTHER APPROVED
FINAL FINISH	ANGLES ±1 DEGREE	ENG. APPROVED	RELEASED 997-002-9704
NOTE: UNLESS OTHERWISE SPECIFIED. 1. REMOVE ALL BURRS AND SHARP EDGES. 2. CHAMFER FIRST THD. ALL TAPPED HOLES. 3. 4.	SURFACE FINISH OR BETTER 125 ✓	"THIS DOCUMENT AND ALL INFORMATION CONTAINED OR IMPLIED HERIN IS THE PROPERTY OF ELWOOD CORP. IT SHALL NOT BE DUPLICATED OR COMMUNICATED TO OTHERS NOR USED FOR PURPOSES OTHER THAN THOSE FOR WHICH IT WAS SPECIFICALLY FURNISHED."	

Elwood Corporation - Motors Group 2701 N. Green Bay Rd Racine, WI, U.S.A			
TITLE OUTLINE DRAWING, SF SERIES, M43X-*N, O-RING FACE SEAL SPEEDTEC CONNECTORS			
SIZE B	SOLIDWORKS CAD	DWG NO 497-243-2141	
SCALE NONE	EDN 072265	SHEET 1 OF 1	

DWG NO 497-243-2141 SH 1