

DESCALE VALVES - SPINDLE STYLE

www.elwood.com

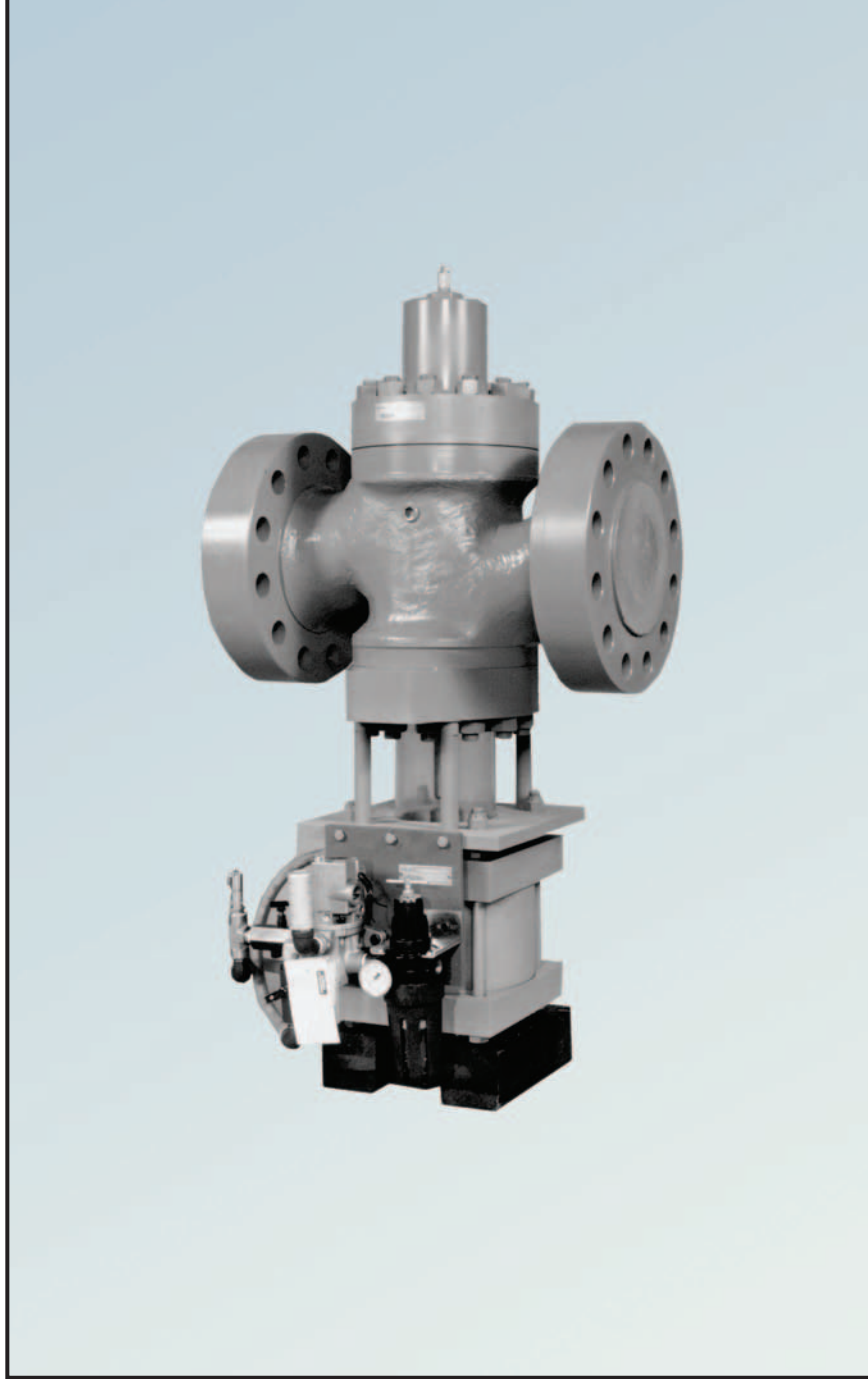

ELWOOD[®]

**FLUID
POWER**

ISO 9001:2000
CERTIFIED COMPANY

Features

With over 60 years of service in the field, Elwood's product line sets the standard by which our competitors follow. Water hydraulics is our specialty.

Our Spindle Style Descale Valve is specifically designed for the Descale environment. Widely used in the steel processing industry worldwide, providing unparalleled service and shock control. Available in normal open or closed positions, with a variety of sizes and mounting configurations, required to provide our customers with the complete solution.

FUNCTION

The main valve consists of a counter balanced spindle controlled by an internal hydraulic cylinder acting on the top of the spindle to generate the force required to close the valve, and a pneumatic air cylinder located on the bottom of the valve that is actuated to open the valve. The pneumatic cylinder's position (open or closed) is controlled by an electrically-operated pneumatic solenoid, supplying air to the pneumatic cylinder. The opening and closing speed of the valve can be controlled by regulating the air flow entering or exiting the pneumatic cylinder.

FEATURES

- Designed to operate with low viscosity fluids and raw water
- Excellent corrosion-resistance
- Shield Seat Design
- Inverse Flow Technology
- Removable Stainless Steel internal parts
- V-Notch Shock Technology with Velocity Control Ports
- Reversible Soft Composition Disc

V-NOTCH SHOCK TECHNOLOGY

Uses specially-designed orifices machined into seat and precision contours on the spindle assembly to control flow and reduce hydraulic shock in the system.

As the valve is opened, fluid flows past the disc and is discharged through the special V-Notch orifices machined into the annular area of the seat located above the sealing area of the disc. (1) As the valve closes, the spindle reduces the V-Notch area, rapidly at first (2) then at a decreasing rate for each increment of spindle movement, until, (3) at the very peak of the V-Notch, flow is stopped before the disc is seated. The fluid is brought to rest gradually, eliminating harmful shock or water hammering.

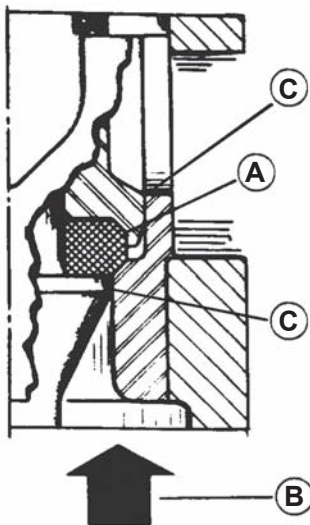
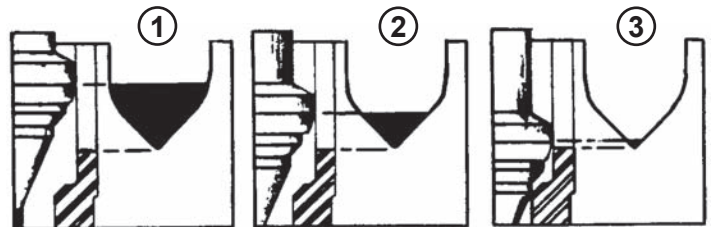

Cross-sectional view through seat area (closed position)

A. Reversible Composition Disc

The soft composition disc is designed to provide reliable maintenance-free drop tight sealing around scratches or scored surfaces between the disc and seat. Damaged discs are easily reversed to provide extended seal life, reducing long term maintenance costs.

B. Inverse Flow Technology

Inverse flow concept uses the direction of fluid flow through that valve in conjunction with the operating direction of the valves spindle. The flow of the fluid through the valve is directly opposing the movement of the valve spindle as it closes. This prevents the spindle from slamming into the valve seat as the spindle approaches the fully-closed position. If fluid flow is in the same direction as the spindle movement, a large imbalance would be created, causing the spindle to slam into the valve seat.

C. Shield Seat Design

Using the different contours on the spindle assembly and the bore diameter in the seat, creates a precision metering system to control the effects of high velocities. When the spindle begins to open, the gap between the seat and the disc accelerates faster than the gap between the spindle and the bores, minimizing the effects of high velocity fluid acting on the seat and disc, providing longer valve life.

Technical Data

Minimum Operating Pressure	40 PSI (3 bar) (Consult factory for pressures below 40 PSI)
Hydraulic Media	HWCF, 97/3 Soluble Oil in Water, Synthetics, Mineral Oils and Kerosene
Viscosity Range at 100° F (38° C)	20 SSU (1.2 Cst.) to 1800 SSU (385 Cst.)
Maximum Pressure Rating	2 Ranges 3600 PSI (248 bar), 6000 PSI (414 bar)
Fluid Temperature Range	HWFC 35° to 150° F (2° to 65° C) Mineral Oil 5° to 150° F (-15° to 65° C)
Recommended Filtration	Minimum - 149 Micron (100 mesh)
Air Pressure	Minimum - 60 PSI (4 bar) Maximum - 120 PSI (8 bar)

Valve Sizing

Valve sizing and selection requires consideration in two (2) areas: Pipe Velocity and Pressure Drop through the valve.

PIPE VELOCITY

Allowable maximum pipe velocity is based on various system considerations and fluid velocity and resulting pressure drop. Generally, the following flow rates are acceptable parameters for most piping systems:

- for short-to-medium length runs, 26 ft/sec (8 m/sec.), and a maximum of 30 ft/sec. (9 m/sec.)
- for long piping runs, 20 ft/sec. (6 m/sec.)

PRESSURE DROP THROUGH THE VALVE

For peak performance and extended valve life pressure drop through the valve should be a consideration. Use the manufacturer's stated Cv Factor as an effective method in calculating a valve's pressure drop.

$$1. \Delta P = \left(\frac{\text{GPM}}{\text{Cv}} \right)^2$$

$$2. \text{Cv} = \sqrt{\frac{\text{GPM}^2}{\Delta P}}$$

$$3. \text{GPM} = \text{Cv} \sqrt{\Delta P}$$

ΔP = Pressure drop (PSI)
GPM = Flow (GPM)
Cv = Cv factor

Flow and Capacity Curves

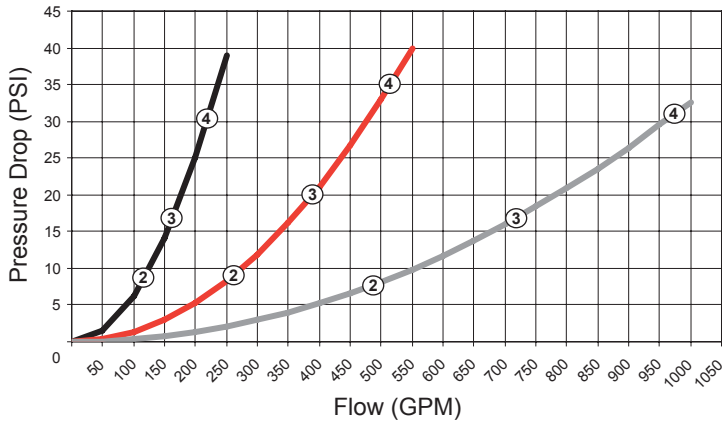

MODELS:

- 4104A
- 4106A
- 4108A

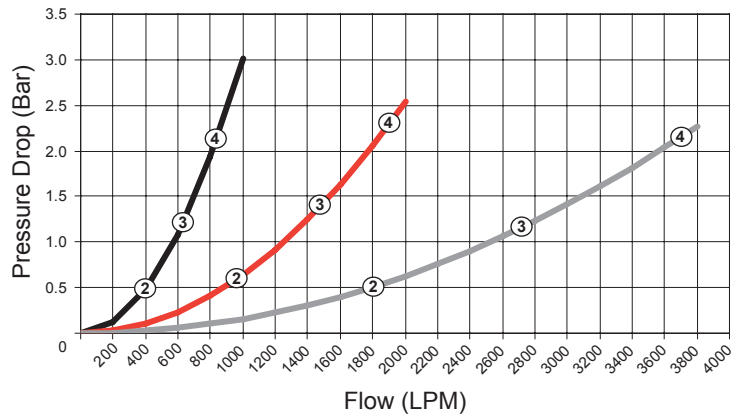

FLOW RATES:

- ② - 20 ft/sec (6.1 m/sec)
- ③ - 30 ft/sec (9.1 m/sec)
- ④ - 40 ft/sec (12.2 m/sec)

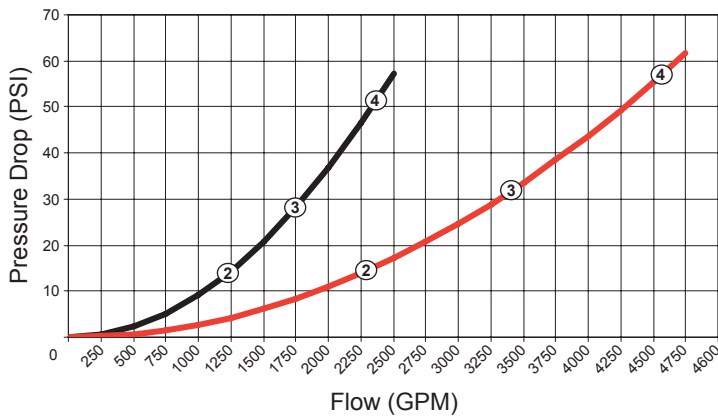

MODELS:

- 4110A
- 4112A

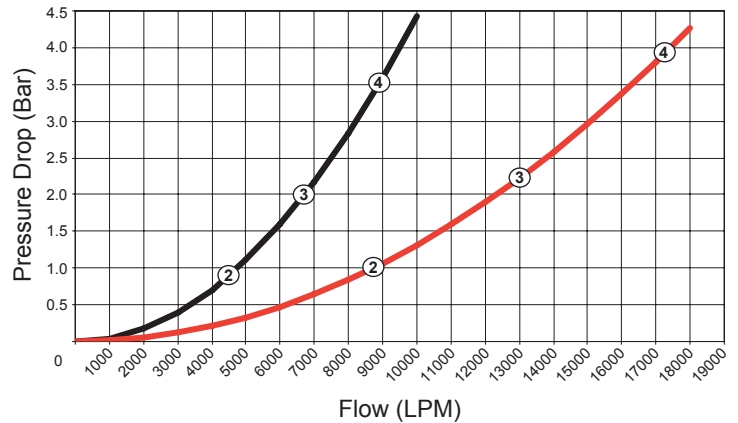

FLOW RATES:

- ② - 20 ft/sec (6.1 m/sec)
- ③ - 30 ft/sec (9.1 m/sec)
- ④ - 40 ft/sec (12.2 m/sec)

3600 PSI (250 Bar) Series

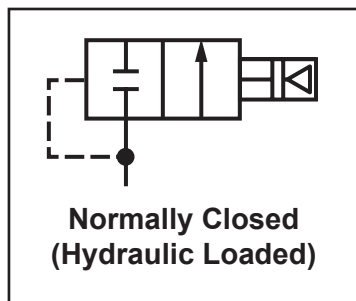
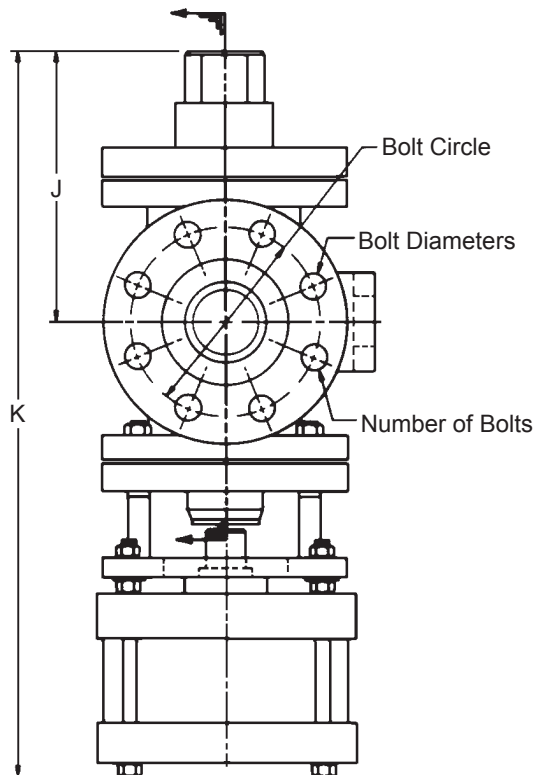
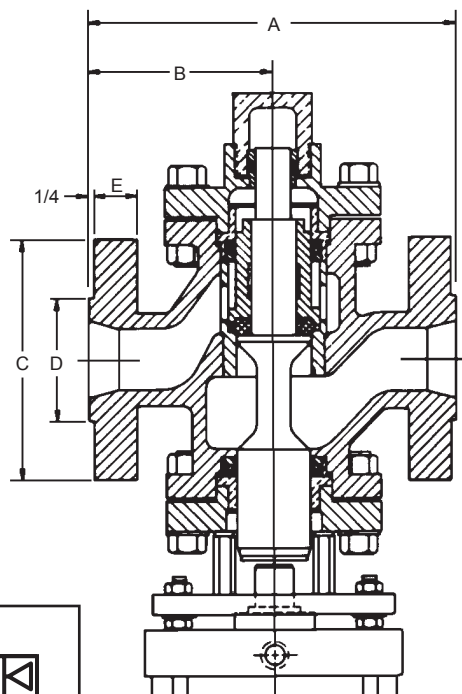

DIMENSIONAL DATA - 1500 LB. ASA B16.5 FLANGES

SIZE	MODEL	CV FACTOR	A	B	C	D	E	BOLT CIRCLE	BOLT DIAMETER	NUMBER OF BOLTS	J	K
2	4104A	40	10.12	5.06	8.50	6.50	3.38	1.50	1.00	8	7.62	22.12
			257	129	216	165	86	38	25		194	562
2 1/2	4105A	40	10.12	5.06	9.62	7.50	4.12	1.62	1.12	8	7.62	22.12
			257	129	244	191	105	41	28		194	562
3	4106A	87	15.00	7.50	10.50	5.00	1.88	8.00	1.25	8	9.25	25.75
			381	191	267	127	48	203	32		235	654
4	4108A	175	18.50	9.25	12.25	6.18	2.12	9.50	1.38	8	14.00	14.00
			470	235	311	157	54	241	35		406	953
6	4110A	330	24.50	12.25	15.50	8.50	3.25	12.50	1.50	12	18.50	44.75
			622	311	394	216	83	318	38		470	1137
8	4112A	605	33.50	16.75	19.00	10.62	3.62	15.50	1.75	12	21.25	53.25
			851	425	483	270	92	394	44		540	1353

□ = Inches; ■ = Millimeters

Consult Factory for additional configurations or flange sizes. Above dimensions are for reference only. All dimensions are subject to change.

6000 PSI (413 Bar) Series

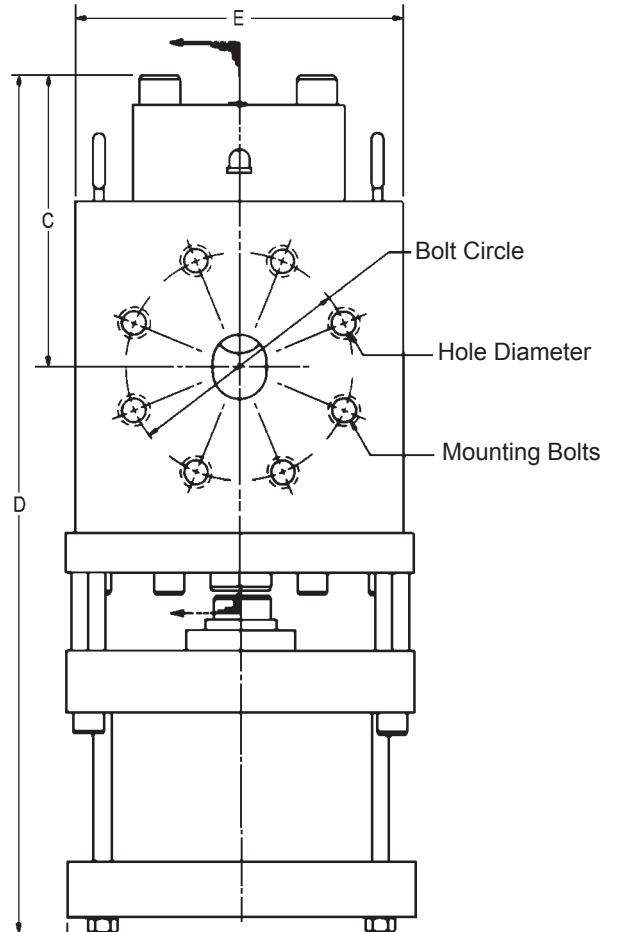
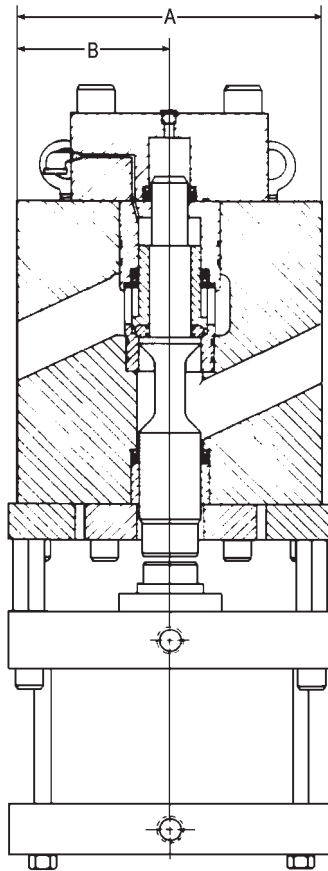
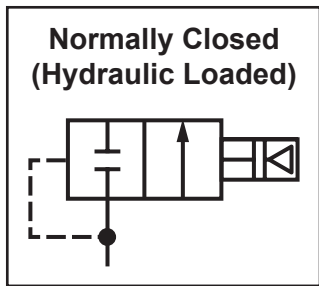

DIMENSIONAL DATA - 2500 LB. ASA B16.5 FLANGES

SIZE	MODEL	CV FACTOR	A	B	C	D	E	BOLT CIRCLE	MOUNTING BOLTS	NUMBER OF BOLTS
2 1/2	4105A	40	10.38 264	5.19 132	8.68 220	24.68 627	8.00 203	7.75 197	1 1/8" - 7 UNC	8
3	4106A	87	12.00 305	6.00 152	10.50 267	29.32 745	12.00 305	1.62 41	1 1/8" - 7 UNC	8
4	4108A	175	20.25 514	10.12 257	14.75 374	37.62 955	14.00 355	10.75 273	1 1/2" - 8 UNC	8
6	4110A	330	27.38 695	13.69 347	16.25 412	40.75 1034	19.75 501	14.50 368	2" - 4.5 UN	8
8	4112A	605	33.50 850	16.75 425	21.25 539	31.75 806	22.00 558	17.25 438	2" - 4.5 UN	12

☐ = Inches; ■ = Millimeters

Consult Factory for additional configurations or flange sizes. Above dimensions are for reference only. All dimensions are subject to change.

Ordering Data - Descale Air Actuated Valves

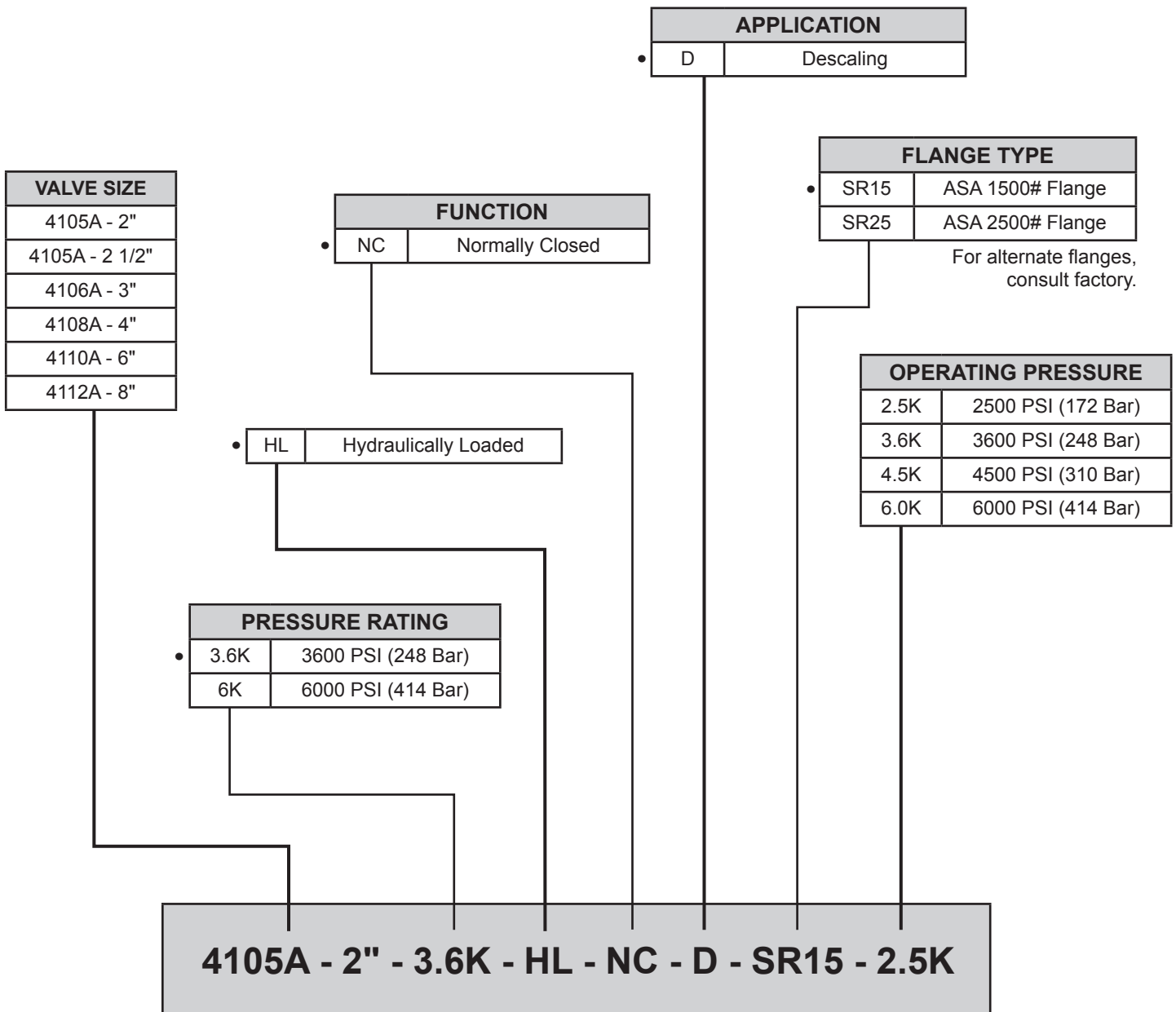

Code No. Example:

• Denotes standard features.

Refer to Elwood Options Brochure (number 2221) for available valve options.

Packed Spool Directional Control Valves

- Directional Valve for a range of applications
- Up to 46 GPM (32 GPM nominal)
- 3000 PSI (207 bar) and 6000 PSI (414 bar)

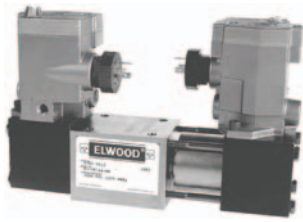

- Air Solenoid Operated
- 3-position spring centered
- 2-position spring offset
- 2-position momentary contact

Brochure 82

Poppet Type Directional Control Valves

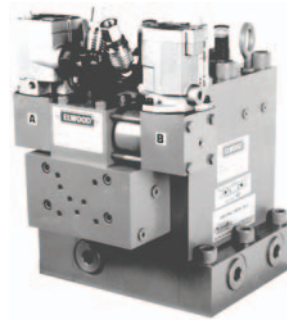

- Capacities to 1600 GPM (6057 LPM)
- 3000 PSI (207 bar), 4500 PSI (310 bar) and 6000 PSI (414 bar) models are available
- Built-in flow control
- Manifold mounted, NPT, socket weld or flanged

Brochure 395

Proportional Pressure Control System

Controlled Pressure Ranges:

390 PSI (27 bar) to 1500 PSI (103 bar)
 480 PSI (33 bar) to 3000 PSI (207 bar)
 580 PSI (40 bar) to 6000 PSI (414 bar)
 FLOW RATE: To 1000 GPM (3785 LPM)

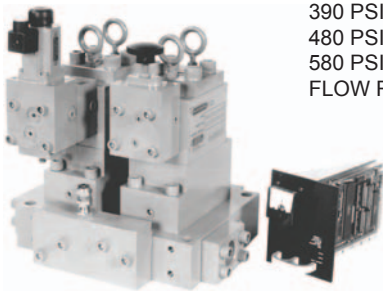

Brochure 104

Modular ISO-Lock

- Isolates manifold mounted directional control valves
- Reduces maintenance time - replace Directional Valves without depressurizing and draining hydraulic system
- Single lever operation to close all four ports (P, T, A, B). Cylinders can remain under the external load without having to be blocked
- Lockable per OSHA safety standard
- NFPA "DO"/CETOP and special mounting patterns available



Brochure 250

Descaling & Pump Unloading Valves

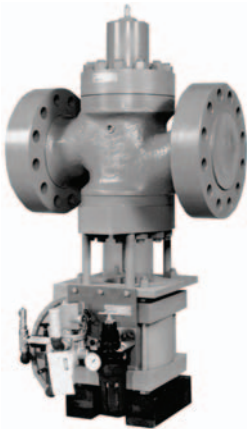

Capacities:

3000 PSI (207 bar)
 6000 PSI (414 bar)
 6000 GPM (22710 LPM)

Connection Sizes: 1-1/4" to 10"

Descaling Valves - Spindle – Brochure 2218
 DIN – Brochure 2219
 Pump Unloading Valves – Brochure 2213

Accumulator Systems

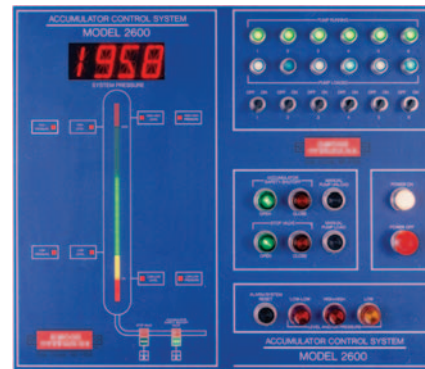

- Descaling
- Mill Systems
- Presses
- Controls
 - Level
 - Pressure
 - Pump Sequencing
 - Ballast Charging
- Designed to your specifications

Brochures 105, 380 & 102



ELWOOD CORPORATION

195 West Ryan Road • Oak Creek, Wisconsin 53154 • USA

Phone: 800-527-7500 • Fax: 414-764-4298

www.elwood.com

1/07 - Brochure 2218

Rev. A

Printed in the U.S.A