

No. 4 - Industrial Flex Shaft

For Use With 1 and 1-1/2 hp Motors

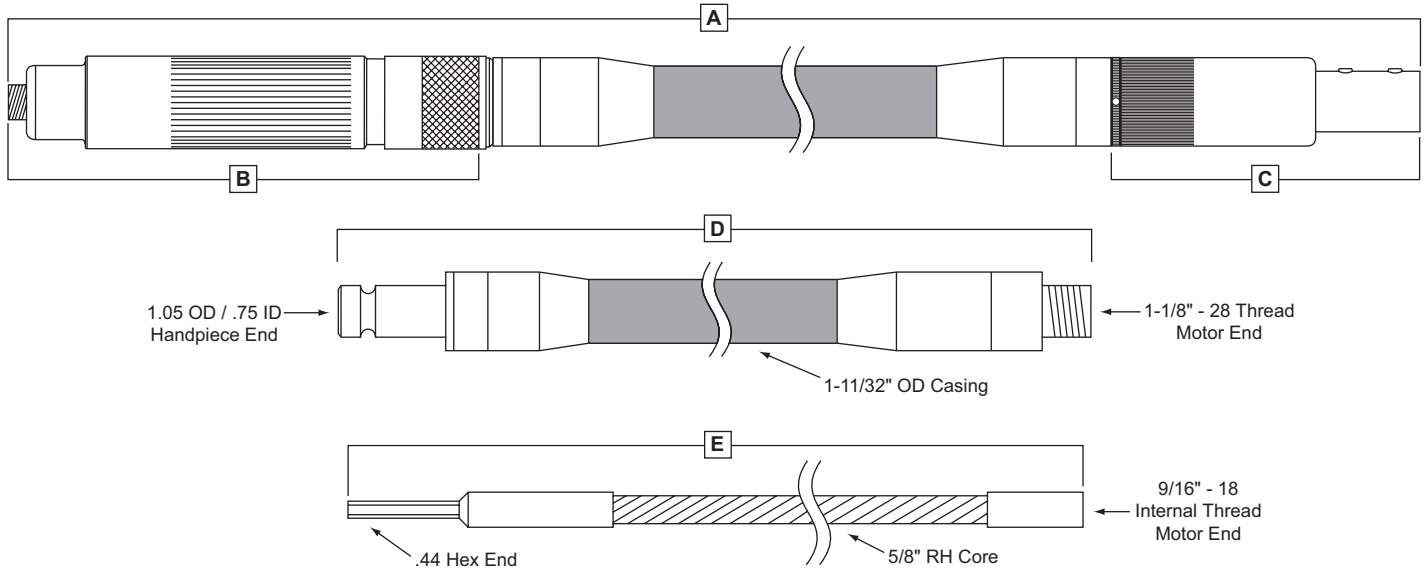

Item "A" #481-506 — Assembly, #4 Industrial Flex Shaft; 5/8" I.D. (7 ft. long)

Item	EPN	Description
B	555-510	Assembly, Handpiece, 551 (Spindle is 9/16" - 18" Thread)
C	345-500	Assembly, Coupling; Motor; 550-MP 5/8" I.D. Size
D	211-507	Assembly, Casing, K-4 (Overall Length is 79 1/2")
E	321-507	Assembly, Core, C-4 (Overall Length 81-7/8")

Item "A" #481-507 — Assembly, #4 Industrial Flex Shaft; 3/4" I.D. (7 ft. long)

Item	EPN	Description
B	555-510	Assembly, Handpiece, 551 (Spindle is 9/16" - 18" Thread)
C	345-503	Assembly, Coupling; Motor; 550-MP 3/4" I.D. Size
D	211-507	Assembly, Casing, K-4 (Overall Length is 79 1/2")
E	321-507	Assembly, Core, C-4 (Overall Length 81-7/8")

For a detail drawing of item "B" and "C", see other side of page.

General Instructions

The above #4 is 7 ft. long with a Ball Bearing Motor Coupling to fit the customer's Motor or Power Drive with a 5/8" or 3/4" driveshaft. Elwood-Wyco Wheel Arbors for grinding wheels, wire brushes, etc. with 3/8", 1/2" or 5/8" arbor holes are available. There are also Rasp Adapters for using Rasps with internal threads of 3/8" - 16 and 1/2" - 13.

No. 4 - Industrial Flex Shaft

For Use With 1 and 1-1/2 hp Motors

No. 551 "Quick Change" HANDPIECE

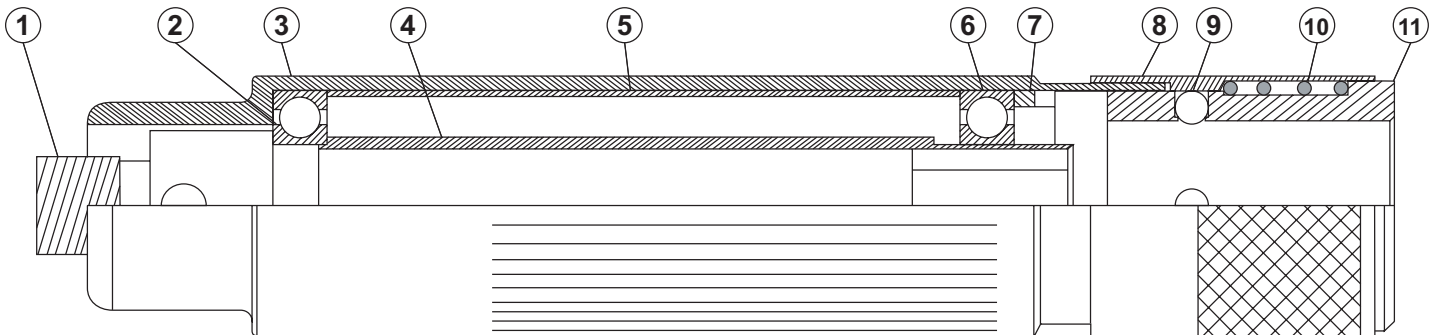

PARTS LIST

Item	EPN	Qty.	Description
1	795-072	1	Spindle, #507-P
2	098-334	1	Bearing, Ball; Sealed
3	765-501	1	Shell, Handpiece; Black
4	385-442	1	Sleeve, Hex
5	785-280	1	Spacer, Bearing
6	098-332	1	Bearing, Ball; Shielded

Item	EPN	Qty.	Description
7	708-380	1	Ring, Lock
8	765-322	1	Sleeve, Quick Change
9	091-400	4	Ball, Steel
10	805-320	1	Spring, Quick Change
11	778-380	1	Socket, Handpiece

No. 550 Ball Bearing Motor Coupling

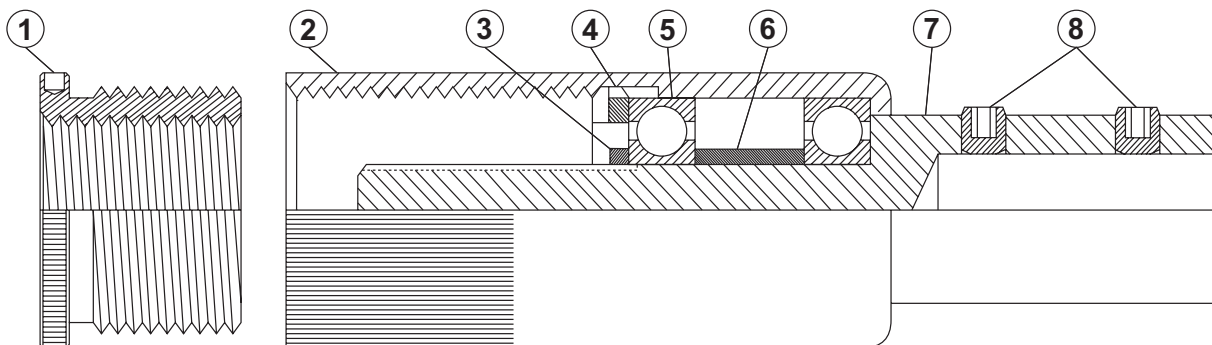

PARTS LIST

Item	EPN	Qty.	Description
1	175-360	1	Bushing, Reducing
2	765-502	1	Shell, Coupling; Plated
3	432-545	1	Nut, Hex Lock
4	708-380	1	Ring, Lock
5	098-334	2	Bearing, Ball

Item	EPN	Qty.	Description
6	785-282	1	Spacer, Motor Coupling
7	345-451	1	Coupling, Motor; 5/8"
7	345-452	1	Coupling, Motor; 3/4"
8	434-030	2	Screw, Set, 5/16" - 18"

Maintenance and Lubrication Instructions

Handpiece: Bearings are lifetime lubricated and need no further lubrication. To remove bearings for replacement: (a) Remove socket by using flat side or wrench in slot of socket. (b) Remove Lock Ring (4). Bearing assembly (3, 5, 6, 7 & 8) will now slide out. (c) Clean parts with a clean cloth. **DO NOT** dip bearings in solvent.

Coupling: To detach core from coupling after casing is removed: (a) Fasten locking pliers over core end. (b) Hold coupling in vise. (c) Turn Pliers (R.H. threads) and remove core end. To disassemble coupling: (a) Remove reducing bushing (1) (b) Remove lock ring. The coupling and bearing assembly will slide forward for removal (c) Remove hex nut (3). Bearings are now free for removal.

Flex Shaft: Lubricate core after every 50 hours of operation using Elwood-Wyco lubricant. Loosen the casing to expose about 18" of core and apply a liberal amount of lubricant to the exposed section of core and re-install the casing. The lubricant will travel the full length of the shaft when in use.