

No. 1 - Industrial Flex Shaft

Used For: Light Duty Grinding, Sanding,
Wire Brushing, Polishing, etc.

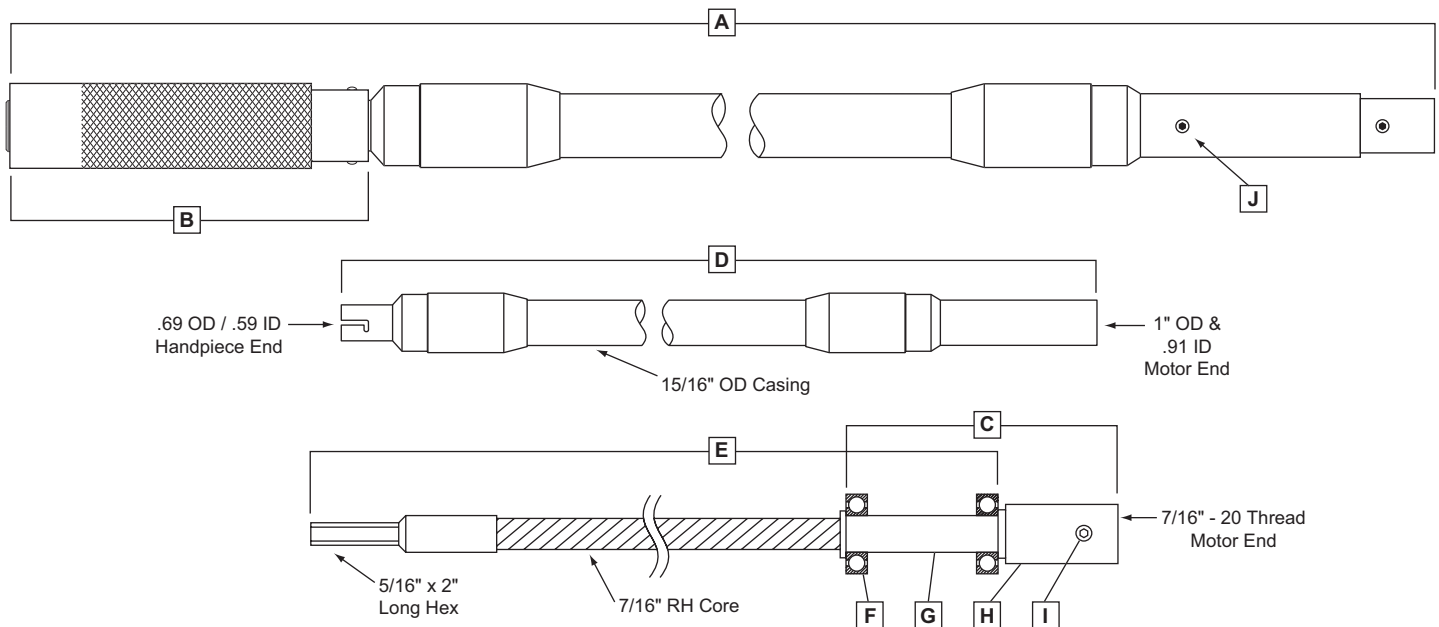

Item "A" #481-024 – Assembly, Industrial Flex Shaft; 1/2" Diameter (5 ft. long)

Item	EPN	Description
B	552-510	Assembly, Handpiece (Spindle is 9/16" - 18" Thread)
C	342-455	Assembly, Ball Bearing Coupling; 1/2" Size (Includes F, G, I and 1/2" H items above)
D	211-025	Casing, Flexible Shaft (Overall Length is 57")
E	321-025	Core, Flexible Shaft, 3/8" Dia; 5/15" Hex; 7/16" - 20" Thread (Overall Length 58-3/8")
F	091-051	Ball Bearings (Two Required)
G	782-450	Spacer
H	342-041	Motor Coupling, 1/2" I.D. Size
I	434-030	Set Screw, Socket Head; 5/16" - 18" x 1/4"
J	435-628	Screw, Pan Head Slotted; #4 x 3/16"

Item "A" #481-025 – Assembly, Industrial Flex Shaft; 5/8" Diameter (5 ft. long)

Item	EPN	Description
B	552-510	Assembly, Handpiece (Spindle is 9/16" - 18" Thread)
C	342-458	Assembly, Ball Bearing Coupling; 5/8" Size (Includes F, G, I and 5/8" H items above)
D	211-025	Casing, Flexible Shaft (Overall Length is 57")
E	321-025	Core, Flexible Shaft, 3/8" Dia; 5/15" Hex; 7/16" - 20" Thread (Overall Length 58-3/8")
F	091-051	Ball Bearings (Two Required)
G	782-450	Spacer
H	342-048	Motor Coupling, 5/8" I.D. Size
I	434-030	Set Screw, Socket Head; 5/16" - 18" x 1/4"
J	435-628	Screw, Pan Head Slotted; #4 x 3/16"

For a detail drawing of item "B", see other side of page.

No. 1 - Industrial Flex Shaft

Used For: Light Duty Grinding, Sanding,
Wire Brushing, Polishing, etc.

No. 251-N HANDPIECE

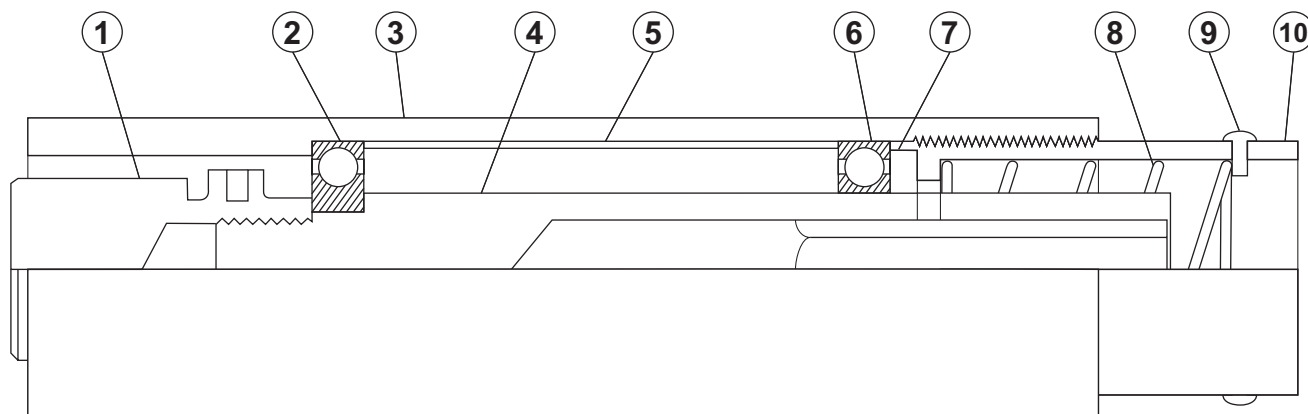

PARTS LIST

Item	EPN	Qty.	Description
1	792-031	1	Spindle
2	091-031	1	Bearing, Ball
3	762-512	1	Sleeve, Handpiece; 251-N
4	382-429	1	Driver, Hex
5	782-280	1	Spacer, 251-N Handpiece

Item	EPN	Qty.	Description
6	091-051	1	Bearing, Ball
7	743-565	1	Washer, Flat
8	802-216	1	Spring, Compression
9	434-217	2	Screw, Drive
10	762-218	1	Socket, Quick Change

Disassembly Instructions: (A) Push in toward shaft, twist left slightly and remove. (B) Remove Quick-Change assembly (Ref. No. 16) from the handpiece. (C) Pull Bearing and spindle assembly out of handpiece shell. The bearings are lifetime lubricated and need no further lubrication. Wipe with clean cloth. **DO NOT** dip bearings in solvent.

Lubrications Instructions: At the end of each working day, or when the machine is to be left idle for period of time, remove the handpiece from the shaft and clean thoroughly with an air hose. Then lubricate parts with fine machine oil. Also, lubricate the open end of the handpiece and the hexagon core end of the flexible shaft. The ball bearings in the handpiece are self-lubricating and require no further lubrication.

Specifications Subject to Change Without Prior Notice