

ELWOOD HIGH PERFORMANCE MOTORS:

Explosion-Proof Servo Motor Technology

August 2016

Overview

- Elwood Corporation, Background Information
- Encompass/Enabled Partner Products (Rockwell Automation)
- Definitions
- Hazardous Location Classification
- Servo Motor Ratings
- Servo Motor Construction
- Connection Diagrams
- Additional Resources
- Elwood Contacts

Elwood Corporation: Background

- Privately held
 - Founded: 1973
- Diverse business groups
 - Electronic Products
 - Fluid Power
 - High Performance Motors
 - High Voltage Capacitors
- ISO9001 Certified: Certificate
 - ATEX, UL Products
 - AS9100 Products



Encompass Partner Products

Background: Elwood Legacy Servo Motors

- Authorized, true drop-in replacements for Rockwell Automation servo motors:
 - S, H, F, N, W, 1326AB, & 1326AS Series
- Website: Elwood's Legacy Servo Motor Website
- Brochure: Elwood's Legacy Motor Program Brochure
- Encompass Website:
Rockwell Automation's Encompass Partner Website



Encompass Partner Products

- Elwood SX-Series (Explosion Proof) Servo Motors
 - M43x, M44x: Class I, Div. 1 & 2, Groups C & D, T4
 - M46x, M47x: Class I, Div.1 & 2, Groups C & D, T3C
 - Class II, Div. 1 & 2, Groups E, F, & G, T3C
 - Website: Elwood's SX-Series Website
 - Brochure: Elwood's SX-Series Brochure
 - Encompass Website:
Rockwell Automation's Encompass Website for SX Series Motors



Enabled Partner

- SX-Series (Explosion Proof) Servo Motors are a Rockwell Automation Enabled Partner Product.
 - Motors integrate as if they were produced by Rockwell Automation product
 - Motor data files included in Logix database
 - Blob files preloaded for self-recognition (on versions with absolute (Stegmann) feedback)



Definitions (From NEC):

- **Hazardous Location:** “Where fire or explosion hazards may exist due to flammable gases or vapors, flammable liquids, combustible dust, or ignitable fibers or flyings.
- **Explosion-Proof (flame proof):** An enclosure designed to contain the explosion of a flammable mixture originating internally without damage and without causing ignition in the external environment.
- **Flame Path:** The joints of a flame proof enclosure designed to contain an internal flame.
- **Increased Safety:** Protection applied to electrical equipment that will not produce arcs and sparks in typical use and specified abnormal conditions.
- **Intrinsic Safety:** Protection where any spark or thermal effect is incapable of causing ignition.

Hazardous Location Classification

- National Electric Code (NEC) sections 500 - 517 classify and specify installation requirements of Hazardous locations.
- The Occupational Safety and Health Administration has oversight for inspecting/evaluating installations in Hazardous locations.
- Typically, organizations will conduct a risk assessment to determine requirements for specific installations
 - Safety committee
 - Consultants

Class I: Gas Atmospheres

- From NEC 500.5: Class I locations are those in which flammable gases, flammable liquid-produced vapors, or combustible liquid-produced vapors are or may be present in the air.

Class I: Division Classification

- **Division 1:** Where ignitable concentrations of flammable gases, vapors or liquids can exist all of the time or some of the time under normal operating conditions.
- **Division 2:**
Where ignitable concentrations of flammable gases, vapors or liquids are not likely to exist under normal operating conditions.

Zone Classification

- Zone Classification is an alternative method to Division Classification from CSA, IEC, and EU Standards
- **Zone 0:** Where ignitable concentrations of flammable gases, vapors or liquids are present continuously or for long periods of time under normal operating conditions.
- **Zone 1:** Where ignitable concentrations of flammable gases, vapors or liquids are likely to exist under normal operating conditions.
- **Zone 2:** Where ignitable concentrations of flammable gases, vapors or liquids are not likely to exist under normal operating conditions.

Division - Zone Comparison

- Division 1 is equated to Zones 0 and Zone 1
- Division 2 is equated to Zone 2
- Zone Classification is the method used by IEC and EU (IECEX, and ATEX)
 - UL has adapted and will list to the Zone system (harmonized with IECEX and ATEX)

Class I - Groups

- Groups define the hazardous chemicals present
- Elwood's SX-Series Class I motors are listed for hazard Groups C & D (ATEX IIB & IIA)
- **Division Classification:**
 - Group A: (acetylene)
 - Group B (hydrogen)
 - Group C (ethylene)
 - Group D (propane)
- **Zone Classification:**
 - IIC (acetylene & hydrogen)
 - IIB (ethylene)
 - IIA (propane)

Class II: Dust Atmospheres

- From NEC 502.1: Class II locations are those in which fire or explosion hazards may exist due to combustible dust

Class II: Divisions, Zones

- Divisions 1 and 2 for Class II environments are equivalent to Class I
- Zones for Class II environments are equivalent to Class I but preceded by '2'
 - Zone 0 (Class I) ~ Zone 20 (Class II)
 - Zone 1 (Class I) ~ Zone 21 (Class II)
 - Zone 2 (Class I) ~ Zone 22 (Class II)

Class II - Groups

- Elwood SX-Series Class II motors are listed for Groups E, F, and G
 - The SX-Series is the only servo product line listed for all the dust groups.
- Groups define the hazardous dust present
 - Group E (metals - Div. 1 only)
 - Group F (coal)
 - Group G (grain)

Temperature Marking

- Temperature markings reflect the maximum surface temperature allowed. For servo motors this marking reflects the motor's maximum surface temperature while rms current remains at or below the motor's continuous current rating.
- SX-Series motors include over-temperature limits (OTL's). This is a set of normally-closed (bi-metal thermal) contacts that open when the motor is operated with rms current above the motor's continuous current rating. The OTL's are tested to open before the motor's surface temperature exceeds the temperature marking. The OTL's automatically reset.
- OTL's are the only contacts internal to the motor.

• Temperature markings	T1 = 450°C	T3C = 160°C
	T2 = 300°C	T4 = 135°C
	T3 = 200°C	T5 = 100°C
	T3A = 180°C	T6 = 85°C
	T3B = 165°C	

- M43x and M44x Motors are marked T4 for UL (T3 for ATEX)
- M46x and M47x motors are marked T3C for UL (T3 for ATEX)

Motor Ratings

- Division System (Example)

Class I Div. 1 Group C T3

- Class I: Gas Atmosphere
- Div. 1: Division 1 - Continuous presence of hazard
- Group C: Ether type hazard (group)
- T3: Maximum surface temperature - 135°C

- Zone System (Equivalent Example)

Class I Zone 1 A Ex d IIB T3

- Zone 1: Likely presence of hazard
- A Ex: US Standard, Explosion Proof
- d: Flame proof enclosure
- IIB: Ether type hazard (group)

Motor Construction

- Materials are certified (tensile tested)
- Tie bolts
- Welded lead wire exit fitting with NPT thread
- Potted conductor exits, Sealed with Kwiko cement
- Seals may be present but not included in flame path
 - Contact Elwood for details on sealed versions
- Assembly fits are calculated, recorded, retained and verified against approved construction requirements (verification)
- Class II motors incorporate a slinger at the shaft to prevent dust ingress
- Repairs must be conducted at the factory to maintain motor rating/certification

Motor Construction

Flame Path Joints

Precision fits to prevent any hot gas or flame from exiting the enclosure. Every component and assembly measured and validated for proper joint fit.

Lead Exit

Welded, pressure tested, and sealed with hazardous location rated cement.

MIX, FILL, AND CURE 4N PER DRAWING 171-008-0014. FILL FITTING TO TOP. WIRES MUST NOT TOUCH EACH OTHER OR THE FITTING AFTER POTTING. REMOVE EXCESS POTTING COMPOUND.

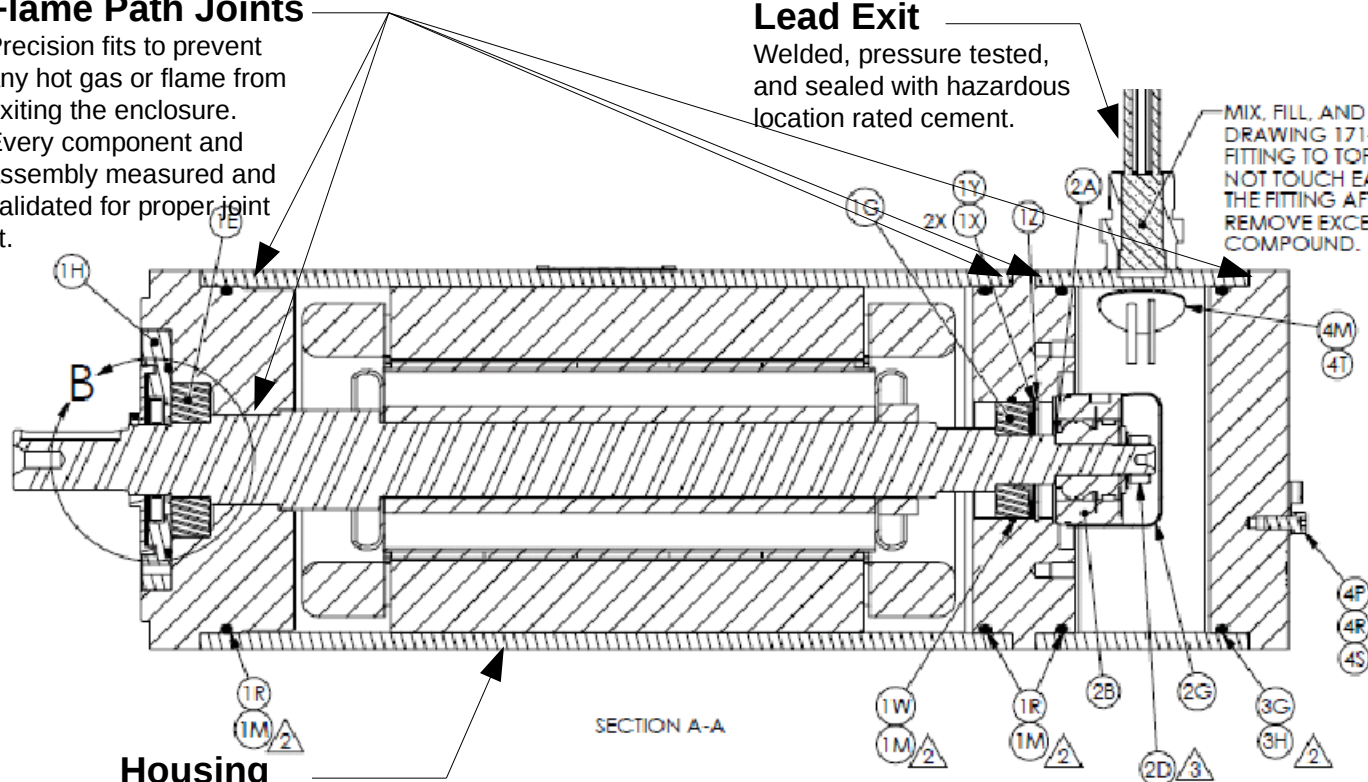

Housing

Controlled design, tested to withstand the pressure generated by an ignition internal to the motor.



Motor Flame Path Fit

DETAIL B SHROTT FLAMEPATH															
FRONTBELL "L"		FRONTBELL "L1"		FRONTBELL "L2"		SHROTT "D1"		"D2" - "D1"		SHROTT "L2"		FRONTBELL "L4"		"D4" - "D2"	
MIN	MAX	MIN	MAX	MIN	MAX	MIN	MAX	MIN	MAX	MIN	MAX	MIN	MAX	MIN	MAX
1.010	1.020	0.198	0.225	1.421	1.425	1.404	1.408	0.013	0.021	1.573	1.577	1.550	1.554	0.013	0.021

DETAIL D FRONT JOINT FLAMEPATH					
	ENDBELL "L"		HOUSING "W"		"L" - "W" SPEC 3/8 (.375) MIN.
	MIN	MAX	MIN	MAX	
LENGTH	0.295	0.325	0.081	0.154	0.375 ID CID SPEC .003 MAX.
DIA	Ø.1990	Ø.1990	Ø.2000	Ø.2010	0.0030

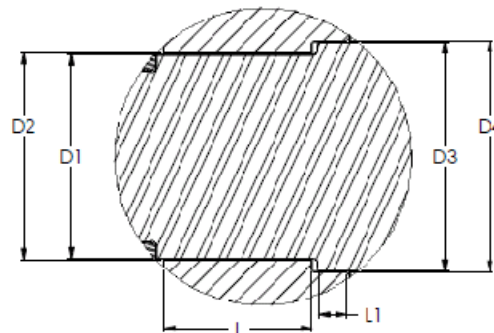
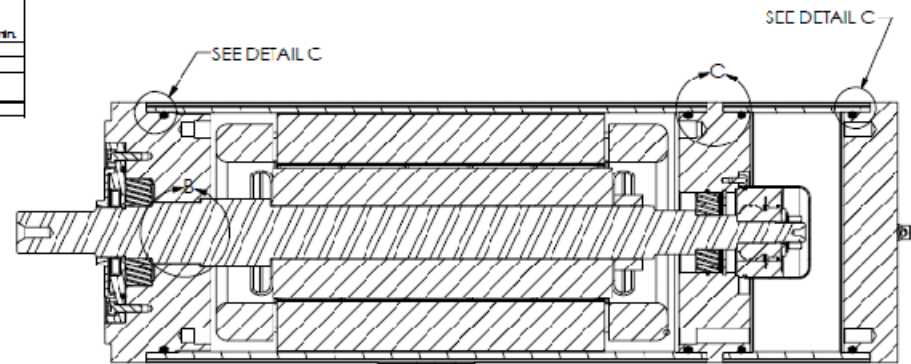

DETAIL B

SECTION A-A

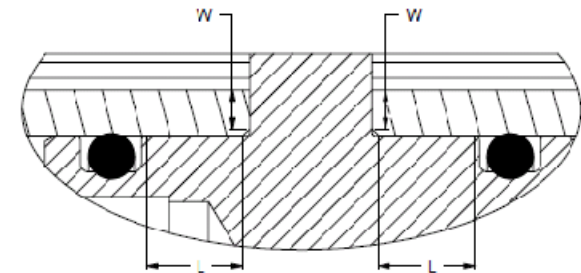

DETAIL C

Connection Diagrams

Click on the following links to connection diagrams for Elwood SX-Series motors with Rockwell Automation Kinetix drives.

- Connection Diagram for SX-Series Motors with Resolvers: [Resolver](#)
- Connection Diagram for SX-Series Motors with Incremental Encoders: [Incremental](#)
- Connection Diagram for SX-Series Motors with Absolute (Stegmann Hiperface) Encoders: [Absolute](#)
- Connection Diagram for SX-Series Motors with Single-Cable Absolute (Stegmann Hiperface DSL) Encoders: [DSL](#)

Additional Resources

- OSHA's website describing and classifying hazardous locations
- UL: Hazardous Location Certification Process
- UL: Hazardous Location Support Brochure
- Adalet: Explosion-Proof Enclosures
- Appleton Electric: Explosion-Proof Enclosures
- Kilark (Hubbell): Explosion-Proof Enclosures
- Expo Technologies: Hazardous Area Solutions

Contact Elwood

- Sales and Customer Service
 - Lisa Woodward lisa.woodward@elwood.com
262-637-6591 ext. 474
 - Linda Richmond linda.richmond@elwood.com
262-637-6591 ext. 413
- Application Assistance
 - Zach Borland Zachary.Borland@elwood.com
262-637-6591 ext. 495