

# 2-WAY VALVES - DIN SERIES

[www.elwood.com](http://www.elwood.com)

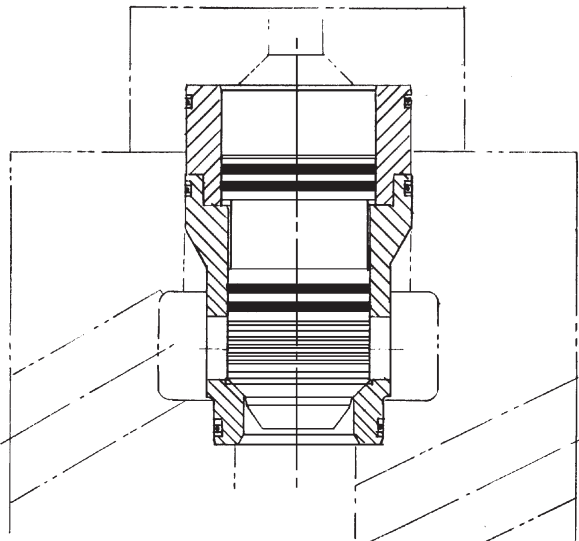

# DIN Cartridge Design



- Hardened Stainless Steel Seat
- Stainless Steel 2 Piece Sleeve
- Stainless Steel Poppet
- Polymer Dynamic Seals - Do Not Cross Ports
- Polymer Static Seals
- Replaceable, Reversible Polymer Disc
- Contoured Nose Piece for Built-In Deceleration and Shock Alleviation
- Sizes 16 to 100 ISO 7368/DIN 24342 and Elwood ED 150 and 200
- Working Pressures to 4500 psi (310 bar) and 6000 psi (414 bar)
- Flow Rates to 3035 gpm (11,490 l/min.)
- Designed for Drop Tight Sealing
- Water-Piloted Actuation from Elwood "P" Series Valve with Air Solenoid Actuator (See Elwood Bulletin 82)
- All Replaceable Parts Easily Accessible by Removing Top Cap

## HOW IT WORKS

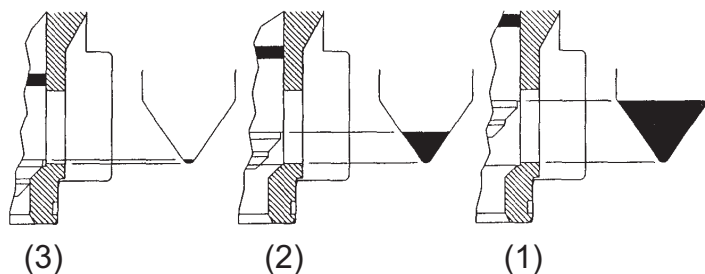

## V-notch shock and velocity control ports

Fluid enters through the connection below the seat. As the valve is opened, fluid flows upward past the disc and is discharged through the special V-notch windows machined in the integral annular sleeve which forms the upper part of the valve seat. (1) As the valve closes, the poppet reduces the V-notch area, at first rapidly, (2) then at a decreasing rate for each increment of poppet movement, until, (3) at the very peak of the V, flow is stopped before the disc is seated. The fluid is thus gradually brought to rest under a nearly pure sine curve action - eliminating harmful shock or water hammer. The reverse transpires during opening. (See B below, left.)

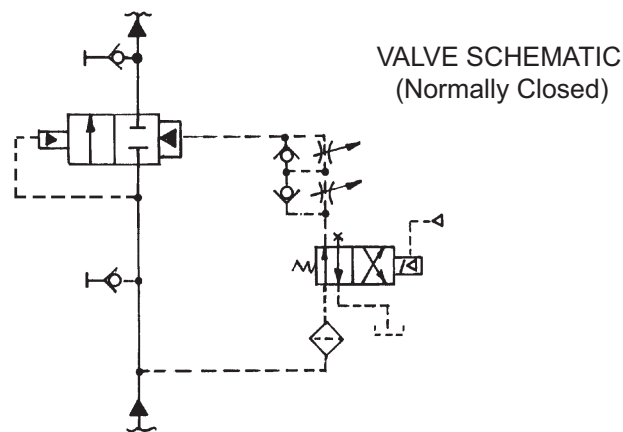

FURNISHED NORMALLY CLOSED FOR DESCALING VALVES  
 FURNISHED NORMALLY OPEN FOR PUMP BY-PASS  
 FURNISHED NORMALLY CLOSED FOR SHUT OFF SERVICE  
 American Standard, Series 1500 and 2500 large male flanges. 1500 and 2500 large male flanges are standard. Other flange types are available, consult the factory.

Elwood Descaling Valve Reduces water hammer shock. Descaling need not be a shocking experience. Here is a unique 2-way pilot operated valve that features a reversible soft disc, V-notch shock and velocity control ports, in conjunction with inverse flow to assure shock free closure during descaling operations.

This unique valve has proved itself unequalled for sustained, low maintenance service under the most severe high pressure operating conditions. It is widely used in steel mills for shut off service, descaling service, and for pump by-pass control. Its shielded seat design and soft, composition disc result in long periods of leakless service. Actual service tests on 1500 PSI filtered river water indicate disc life at up to one million cycles. Because of the inverse flow of liquid through the valve, and the exclusive V-notch throttle ports, shock upon closure has virtually been eliminated.

The valve can be controlled by any standard three way air pilot valve, manually or solenoid operated. All wearing parts are removable when necessary.



The soft composition disc in the Elwood 2-way valve does not allow leaks to start. It is designed to close drop-tight around any foreign particles, scratches or scoring. Foreign particles, trapped between the disc and seat are harmlessly imbedded in the disc, without damaging the stainless steel seat, and are washed away when the valve is opened.



The flow of fluid in this valve opposes the movement of the valve poppet as it closes. This prevents slamming as the poppet approaches the fully closed position - as would happen, due to a large overbalance, if flow were in the same direction as poppet movements.

# Valve Sizing

Valve sizing and selection requires consideration in two (2) areas:

## A) PIPE VELOCITY & PRESSURE DROP

Allowable maximum pipe velocity is based on various system considerations and fluid velocity and resultant pressure drop. Generally, the following flow rates are acceptable parameters for most piping systems:

- for short-to-medium length runs, 26 feet per second (8 meters per second), and a maximum of 30 feet per second (9 meters per second).
- for long piping runs, 20 feet per second (6.5 meters per second).

These parameters consider pressure drop. However, to do a complete engineering analysis, one would need to calculate the length of actual pipe runs, factoring in the number of elbows, valves, etc., to determine the system pressure drop. In this case, Cranes Reference or other reference can be used.

## B) PRESSURE DROP THROUGH THE VALVE

For correct valve sizing, it is necessary to determine pressure drop through the valve. Due to the fact that not all manufacturers clearly state their valve flow characteristics, it may not seem easy to determine the pressure drop. But, it is simple when the Cv is given. The most effective method for comparing alternative valves is by the Cv factors that valve manufacturers provide for each individual valve. This enables engineers to calculate and compare pressure drops at system design flow rates. This will result in selecting valves with a smaller envelope, but superior internal design and flow characteristics and lower valve and installation costs.

$$1. \Delta P = \left( \frac{\text{GPM}}{\text{Cv}} \right)^2$$

$$2. \text{Cv} = \sqrt{\frac{\text{GPM}^2}{\Delta P}}$$

$$3. \text{GPM} = \text{Cv} \sqrt{\Delta P}$$

P = Pressure drop (psi)  
 GPM = Flow (gpm)  
 Cv = Cv factor

Cv Factor for Manifold Mounted Valves			
	2-Way	3-Way	4-Way
DIN 16	5.2	3.2	5.3
DIN 25	11.3	7.9	9.3
DIN 32	16.5	10.5	12.2
DIN 40	29	27	24.5
DIN 50	52.5	49.3	37
DIN 63	75	-	-

(Total Cv for one pass thru the valve body, pressure to cylinder or cylinder return.)

# Pump By-Pass Valve Options



**CIRCUIT 1 - By-pass Valve only**

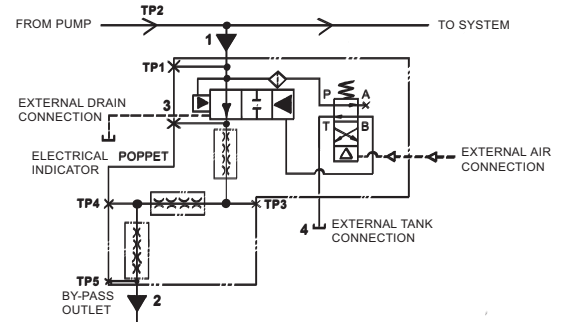

**CIRCUIT 2 - System Check with By-Pass Valve**

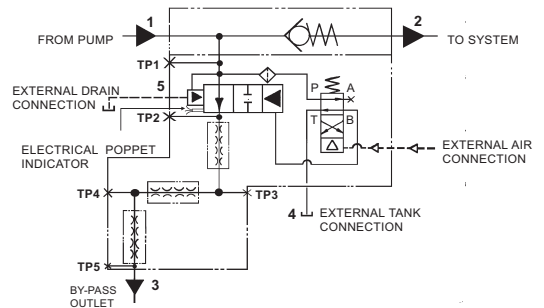

**CIRCUIT 3 - System 2-Way with By-Pass Valve**

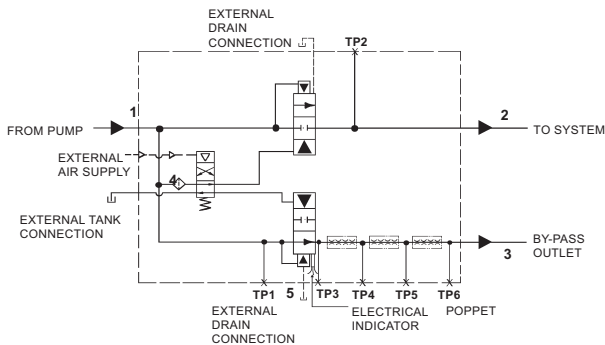

**CIRCUIT 4 - System 2-Way with By-Pass Valve**

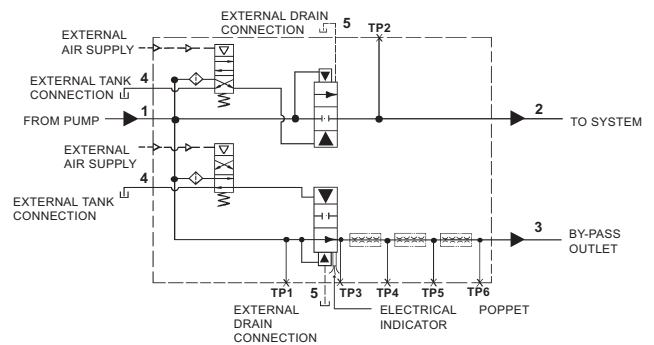

**SIZING INFORMATION REQUIRED**

- Style (Circuit 1, 2, 3 or 4)
- By-Pass Valve Sizing
  - System Pressure
  - Outlet Pressure
  - By-pass flow required
  - Inlet Flange size
  - Outlet Flange size
- System Check Sizing
  - System Flow (Max)
  - Inlet/Outlet Flange sizes
  - By-pass Outlet Flange size
  - Max allowable  $\Delta P$  across valve
  - Optional hydraulically assisted lock-down feature (Y/N)

- System 2-Way Sizing (Circuits 3 or 4)
  - System Flow (Max)
  - Inlet/Outlet Flange size
  - By-pass Outlet Flange size
  - Max allowable DP across valve
  - Single interconnected pilot for both Systems and By-pass 2-Way
  - or
  - Dual Pilots (separate 2-way control)
  - Electrical poppet indicator on system 2-Way (optional)

# Pump By-Pass Valve

Standard Elwood components and proven design concepts packaged into a single valve assembly to meet the requirements of a pump bypass valve, less the full pump flow check valve. If the check valve is required, it is added as an attachment to the pump bypass valve.

The Pump Bypass Valve is of a FAIL OPEN design. Therefore, if air or electrical power is lost, the valve will go to the bypass position. In the bypass position, the "DIN" two-way valve is in the open position, allowing flow to go over a series of orifices that are specifically designed to gradually reduce flow from the predetermined high pressure to atmospheric pressure at a specified flow rate  $\pm 5\%$ .

The orifices utilize our "DIN" sleeve design. They are sized and positioned to eliminate cavitation, fluid vapor pressure, significant vibration, and minimize noise. They are hardened stainless steel for long life, and are easily field replaceable.

## Summary of Operational Features and Benefits:

- Individually profiled and sized "DIN" orifice cartridges of hardened stainless steel. Designed for long life, field replaceable, and can be changed for varying flow rates.
- Nine to sixteen major pressure drop areas, with adjustment on the bypass valve for added pressure drop.
- Large particles can pass without clogging.
- Cavitation eliminated with multistaging.
- Low noise level.
- Standard Elwood components.
- All hardened stainless steel internals with Polymer disc on Bypass Poppet.
- Poppet position indicator available for electrical interlock insuring valve is opened.

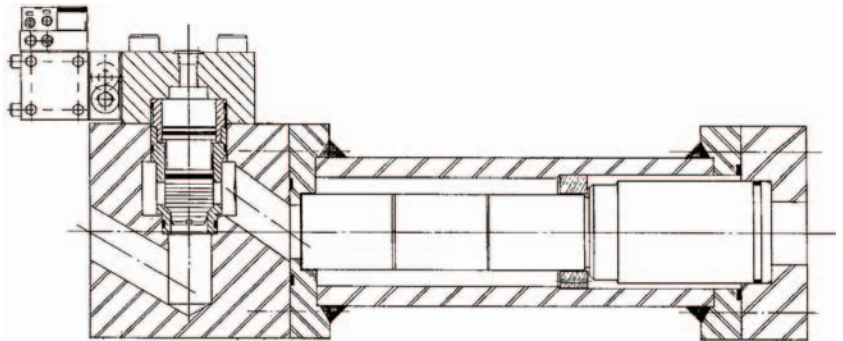

## ELWOOD PUMP BY-PASS CONTROL OPTIONS

In order to assure that the by-pass valve is open when system valves are closed and to monitor valve performance, the following list of options, in various combinations should be used:

- (A) Flow meter on the inlet to the pump
- (B) Flow meter on the discharge of the by-pass valve
- (C) Proximity sensors on the check valve and by-pass poppet
- (D) Pressure transducer on second to last orifice cartridge
- (F) Elwood control panel - designed to interface with a main computer, when desired, the control will perform the following functions:
  1. Display pump status, by-pass valve and all system valve status as needed
  2. Provide a command signal to shut down pumps and sound an alarm in the event of a system malfunction.

# Header Prefill Valve Assemblies

These function to keep the descaling header and associated pipelines full of water to minimize hydraulic shock when the main descaling valve opens. The pre-fill circuit may be fed directly from the low pressure mill water supply system, or at high pressure from the descaling system pump (see circuit examples below).

Elwood can customize a pre-fill valve assembly to fit your application requirements. To provide a specific proposal the following application information is needed:

- Style (Circuit 1, 2, 3 or 4)
- Configuration of Header(s) (i.e. round, octagonal, straight upper/lower)
- Quantity of Nozzles
- Orifice size of Nozzles or brand and model number
- Desired Header Pre-fill Pressure

**Circuit 1** - Low pressure supply via check valve, located between descaling valve and header. Low pressure flow to the headers keep them full when the descaling valve is in the closed position. When the system calls for high pressure descaling flow, the descale valve opens and the check valve in the low pressure supply line is forced closed by the higher pressure.

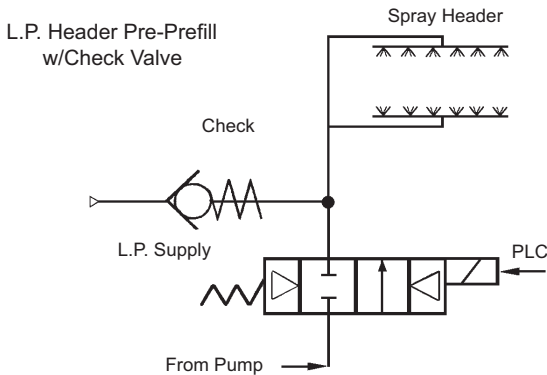

**Circuit 3** - Pressure reducing orifice combined with descaling valve. Flow from the descaling pump is delivered to the headers either at low pressure through the reducing orifice or at full flow high pressure depending on the position of the two-way descaling valve. This eliminates the need for a low pressure supply connection but provides no control over pre-fill flow.

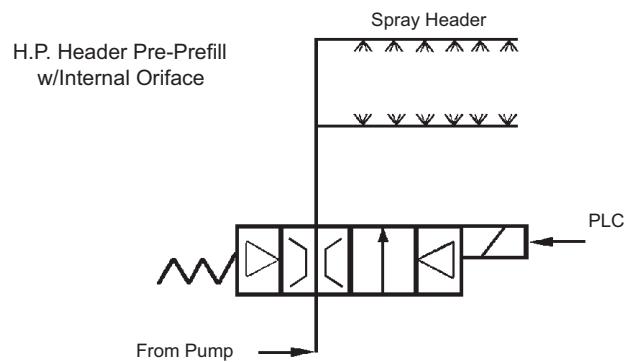

**Circuit 2** - Low pressure supply via an electrically actuated two-way shut-off valve. The shut-off valve replaces the check valve shown in circuit 1 to provide more control over pre-fill flow. The pre-fill two-way valve closes when the descaling valve opens.

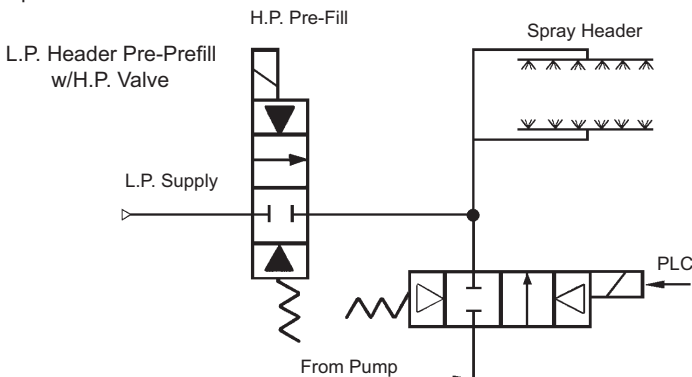

**Circuit 4** - Combination electrically actuated two-way pre-fill valve with reducing orifice and two-way descaling valve. All three functions can be provided in a combination valve package to provide control of flow to the header as well as eliminate the need for a low pressure supply connection.

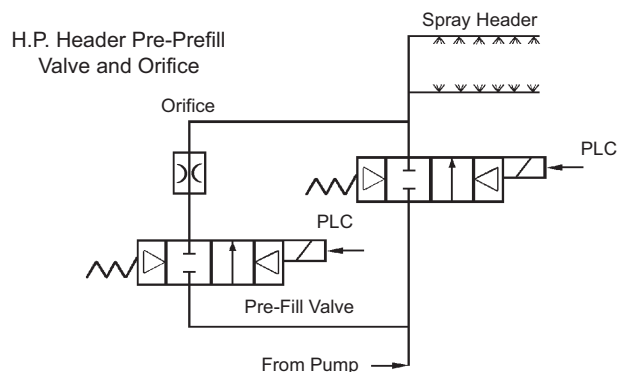

# Connection Styles - 2-Way Valves

**In-Line**

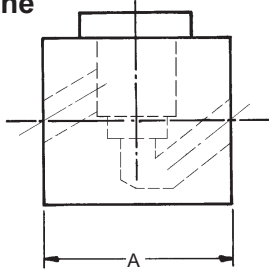

**90° Degree**

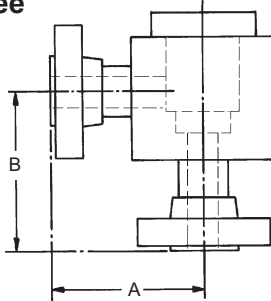

**Offset**

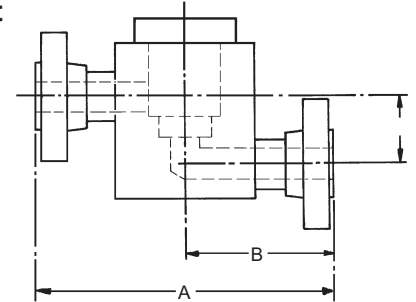

**NOTE:** When requesting a quotation, please identify required A, B & C dimensions if it is necessary to conform to existing piping.

## MODEL NUMBERS

VALVE PORT CONNECTION SIZE					
75 D P		DIN CODE	PORT SIZE	C v 90°	FLOW @ 15/60 D P (GPM)
GPM	LPM				
546	2067	50	3"	63	244 / 488
849	3214	63	4"	98	380 / 759
1247	4720	80	6"	144	558 / 1115
2295	8688	100	8"	265	1026 / 2053
3724	14100	150	10"	430	1665 / 3331
8002	30290	200	10"	924	3579 / 7157

FLANGE SIZE	
DIN NO.	SELECTION RANGE
50	2" to 4"
63	3" to 6"
80	4" to 8"
100	6" to 8"
150	6" to 10"
200	8" to 12"

ELECTRICAL SOLENOIDS	
CODE NO.	VOLTAGE
1	6V. D.C.
2	12V. D.C.
3	24V. D.C.
5	110V. D.C.
6	110/120V. 50/60Hz. A.C.
8	220/240V. 50/60Hz. A.C.
9	410/460V. 50/60Hz. A.C.
10	200V. 50/60Hz. A.C.
11	440/480V. 50/60Hz. A.C.
12	24V. 50/60Hz. A.C.

FUNCTION	
20	NORMALLY CLOSED-(STD)
21	NORMALLY OPEN

OPERATING PRESSURE	
3K	3000 psi (207 bar)
4.5K	4500 psi (310 bar)
6K	6000 psi (414 bar)

FLANGE TYPE	
SR15	SR 1500 FLANGE
SR25	SR 2500
SAE	UP TO 3"
OTHER	SPECIFY; CONSULT FACTORY

CONNECTION STYLE	
N	INLINE
D	90°
Z	OFFSET

OPTIONAL FEATURES	
CODE NO.	DESCRIPTION
10	SEE PILOT VALVE BULLETIN 82
11D	SEE PILOT VALVE BULLETIN 82
11E	SEE PILOT VALVE BULLETIN 82
22	THROTTLE/SPEED CONTROL
33D	INLET OR OUTLET PILOT SUPPLY
40	BLACK "T" BODY CORROSION PROTECTOR
51	EXTERNAL PILOT PRESSURE & DRAIN

CONFIGURATION STYLE	
M	WITH MANUAL LOCK-DOWN HANDWHEEL
MH	WITH MANUAL LOCK-DOWN HANDWHEEL & HYDRAULIC ASSIST

**CODE NO. EXAMPLE** } DIN 63 - 3K - 21 - SR15 - - - 6 - 11D - MH

-DIN SIZES THRU 63 CAN BE MOUNTED IN ANY POSITION.  
 -DIN SIZES 80 & 100, RECOMMENDED TO BE MOUNTED SO THAT THE POPPET IS VERTICAL. FOR EXTENDED SEAL LIFE.  
 -SIZES 150 AND LARGER MUST BE INSTALLED IN VERTICAL POSITION.

## Directional Control Valves Packed Spool 4-Way

- Directional Valve for a Range of Applications  
Up to 46 gpm, 32 gpm Nominal
- 3000 psi (207 bar) and 6000 psi (414 bar)

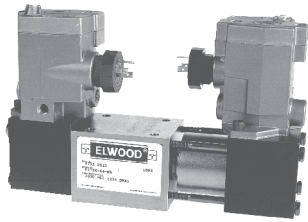

- Air Solenoid Operated
- 3-Position Spring Centered
- 2-Position Spring Offset
- 2-Position Momentary Contact

REQUEST BULLETIN 82

## Directional Control Valves DIN Poppet Series 2-, 3- and 4-Way

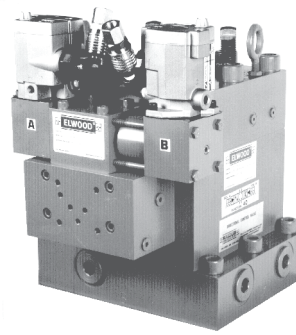

- Capacities to 1600 gpm (6057 l/min.)
- 3000 psi (207 bar), 4500 psi (310 bar) and 6000 psi (414 bar) Models Available
- Built-in Flow Control
- Manifold Mounted, NPT, Socket Weld or Flanged

REQUEST BULLETIN 395

## Proportional Pressure Control System

### CONTROLLED PRESSURE RANGES:

- 390 psi (27 bar) to 1500 psi (103 bar)
  - 480 psi (33 bar) to 3000 psi (207 bar)
  - 580 psi (40 bar) to 6000 psi (414 bar)
- FLOW RATE: To 1000 gpm (3785 l/min.)

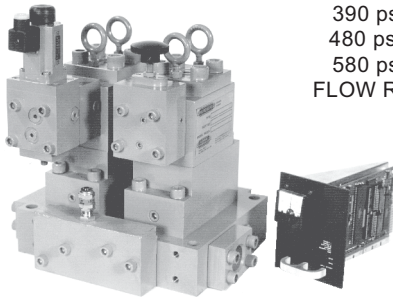

REQUEST BULLETIN 104

## Modular Iso-Lock Valve

- Isolates Manifold Mounted Directional Control Valves.
- Reduces maintenance time - replace Directional Valves without depressurizing and draining hydraulic system.
- Single lever operation to close all four ports (P, T, A, B). Cylinders can remain under external load without having to be blocked.
- Lockable per OSHA safety standards.
- NFPA "DO"/CETOP and special mounting patterns available.



REQUEST BULLETIN 250

## Accumulator Shut-off/Descaling

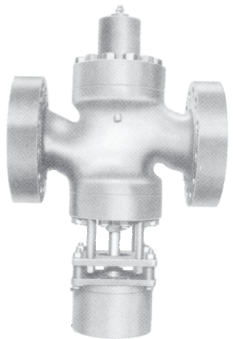

- Capacities: 3000 psi (207 bar)
- 6000 psi (414 bar)
- 6000 gpm (22,710 l/min.)

Connection Sizes: 1-1/4" to 10"

A.S.O. Valves, Request Bulletin 102  
Descaling Valves, Request Bulletin 396

## Accumulator Control Panel

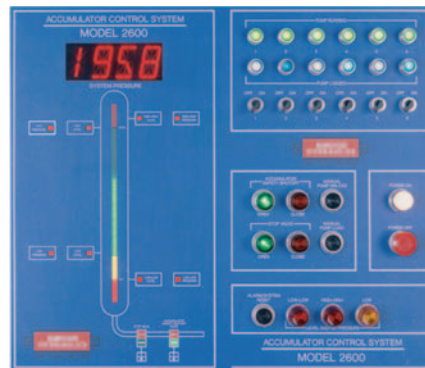

- Descaling
- Mill Systems
- Presses
- Controls
  - Level
  - Pressure
  - Pump Sequencing
  - Ballast Charging

Designed to Your Specifications

Request Bulletins 105 & 380

